

# Brandt



GUIDE D'UTILISATION FR  
USER GUIDE EN  
GEBRUIKSAANWIJZING NL  
BETRIEBSANLEITUNG DE  
BRUGERVEJLEDNING DA  
MANUAL DE UTILIZAÇÃO PT  
MANUAL DE UTILIZACIÓN ES

Four  
Oven  
Oven  
Ovn  
Backofen  
Forno  
Horno



# 1



## 1.1

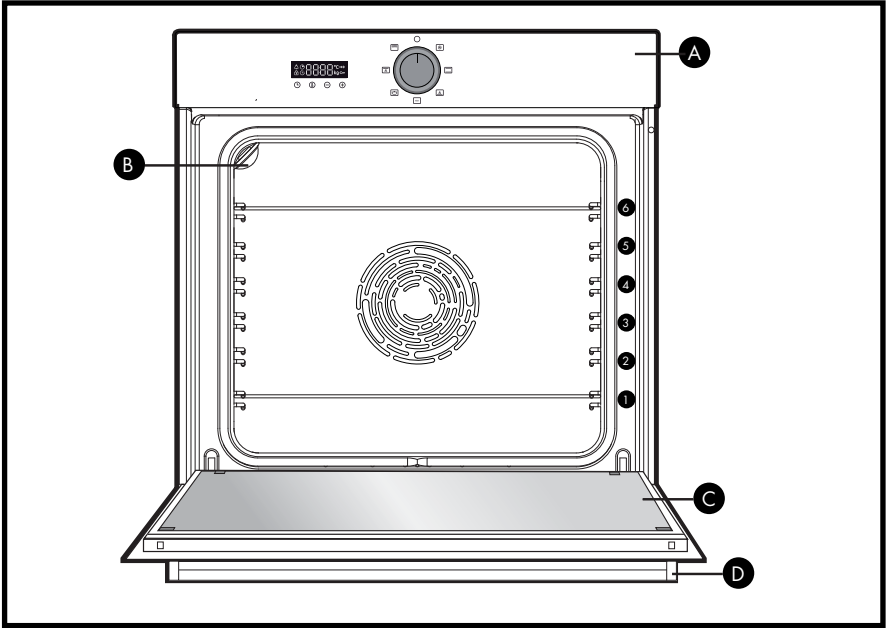

## 1.4

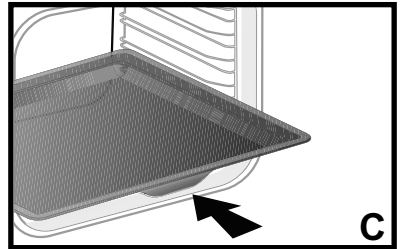
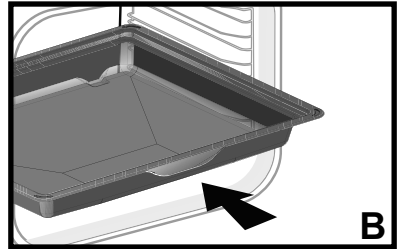
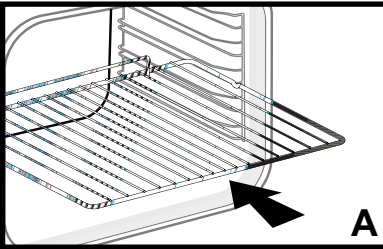

# 2



## 2.1

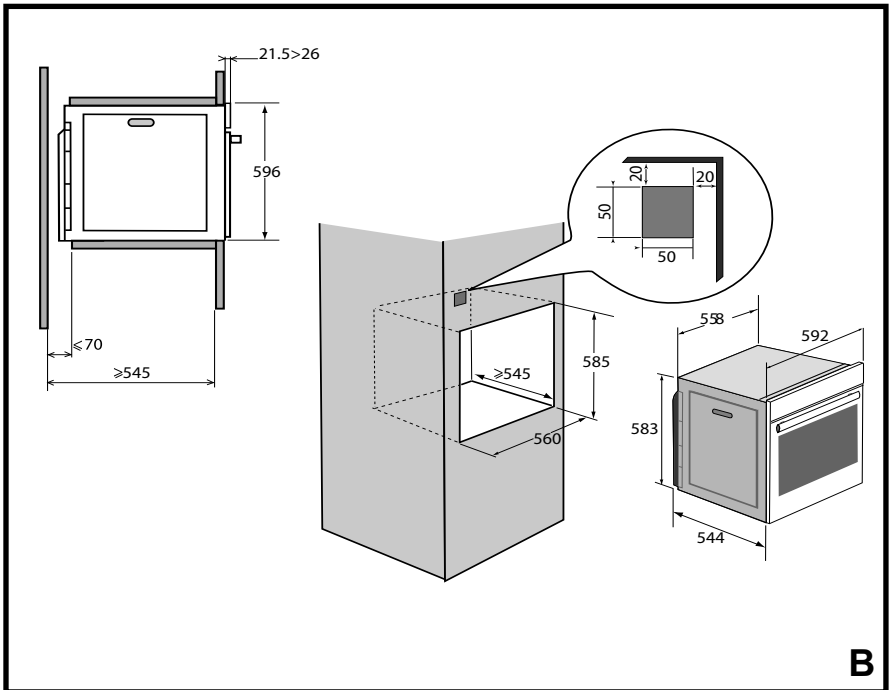
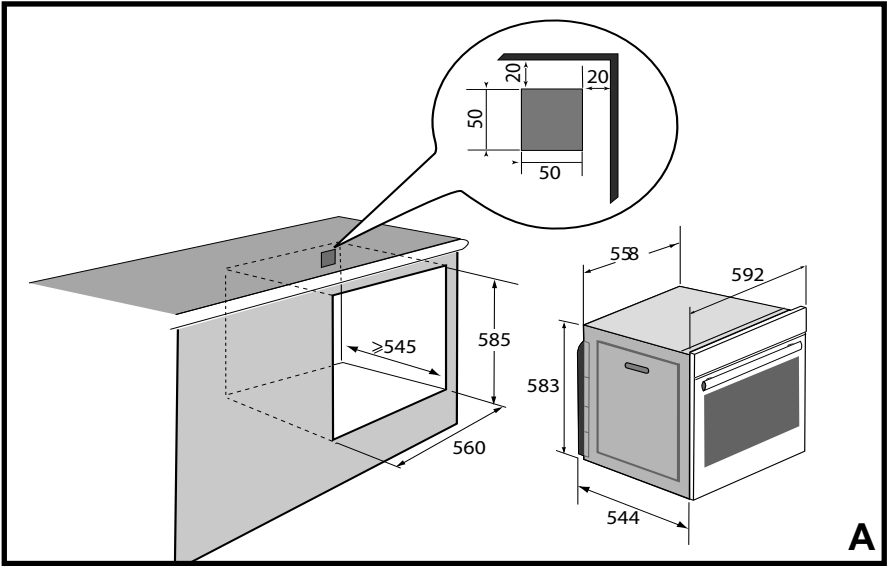

# 3



3.1

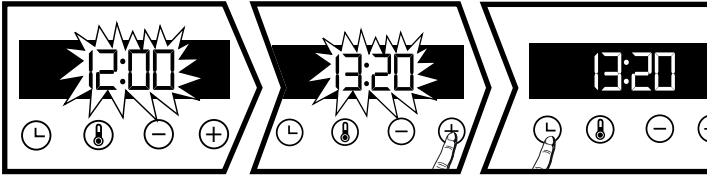

3.2

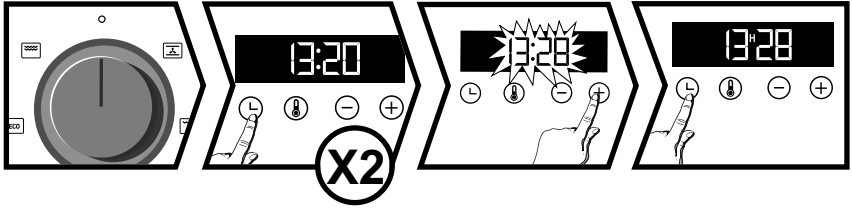

3.3

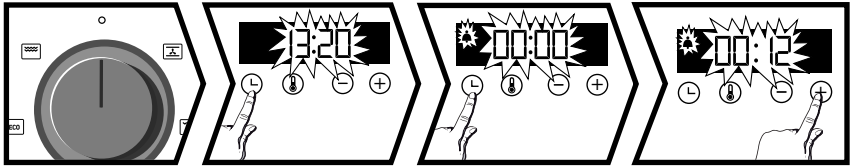

3.4

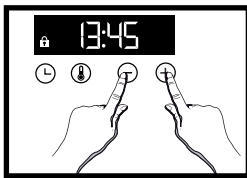

# 4



4.1

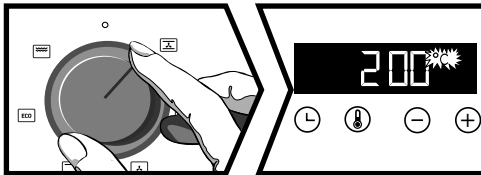

4.2

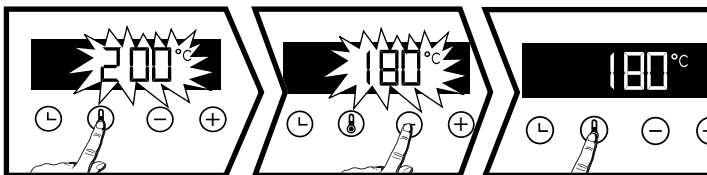

# 4

4.3

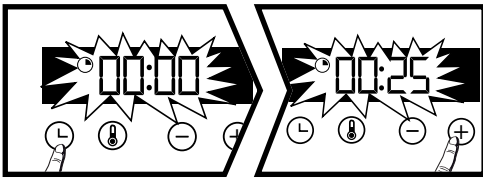

4.4

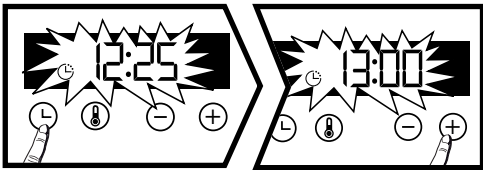

# 5

5.1

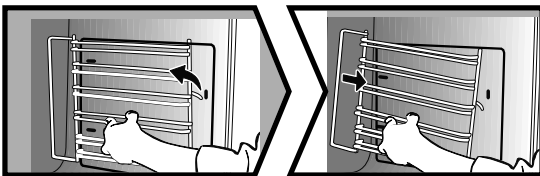

5.2

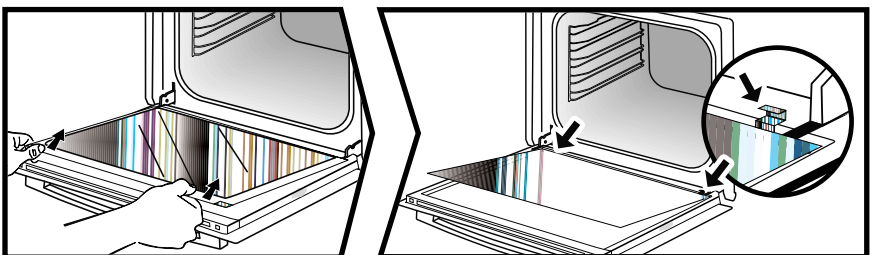
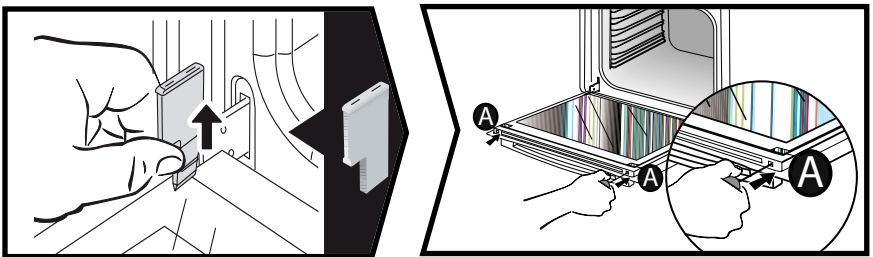

# 5



## 5.2

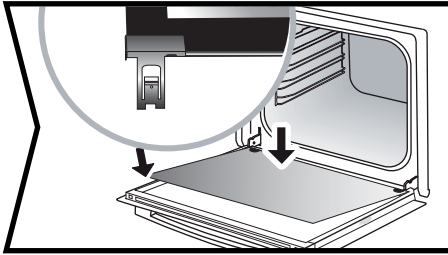

## 5.3

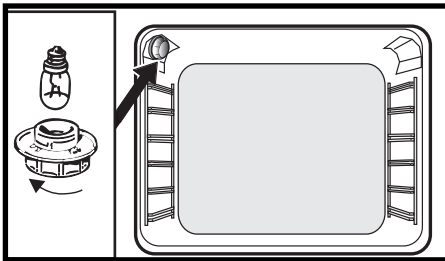



Chère Cliente, Cher Client,

Vous venez d'acquérir un produit **BRANDT** et nous vous remercions de la confiance que vous nous accordez.

Nous avons conçu et fabriqué ce produit en pensant à vous, à votre mode de vie, à vos besoins, pour qu'il réponde au mieux à vos attentes. Nous y avons mis notre savoir-faire, notre esprit d'innovation et toute la passion qui nous anime depuis plus de 60 ans.

Dans un souci permanent de toujours mieux satisfaire vos exigences, notre service consommateurs est à votre disposition et à votre écoute pour répondre à toutes vos questions ou suggestions.

Connectez-vous aussi sur notre site [www.brandt.com](http://www.brandt.com) où vous trouverez nos dernières innovations, ainsi que des informations utiles et complémentaires.

**BRANDT** est heureux de vous accompagner au quotidien et vous souhaite de profiter pleinement de votre achat.



**Important : Avant de mettre votre appareil en marche, veuillez lire attentivement ce guide d'installation et d'utilisation afin de vous familiariser plus rapidement avec son fonctionnement**

## INSTRUCTIONS DE SECURITE

### INSTRUCTIONS DE SÉCURITÉ IMPORTANTES LIRE AVEC ATTENTION ET GARDER POUR DE FUTURES UTILISATIONS.

Cette notice est disponible en téléchargement sur le site internet de la marque.

A la réception de l'appareil, déballez-le ou faites-le déballer immédiatement. Vérifiez son aspect général.

Faites d'éventuelles réserves par écrit sur le bon de livraison dont vous gardez un exemplaire.



**Important :**

Cet appareil peut être utilisé par des enfants âgés de 8 ans et plus, et par des personnes aux capacités physiques, sensorielles ou mentales réduites, ou dénuées d'expérience et de connaissance, si elles ont pu bénéficier d'une surveillance ou d'instructions préalables concernant l'utilisation de l'appareil de façon sûre et en ont compris les risques encourus.

— Les enfants ne doivent pas jouer avec l'appareil. Les opérations de nettoyage et de maintenance ne doivent pas être faites par des enfants laissés sans surveillance.

— Il convient de surveiller les enfants pour s'assurer qu'ils ne jouent pas avec l'appareil.

**MISE EN GARDE :**

— L'appareil et ses parties accessibles deviennent chaudes au cours de l'utilisation. Faire attention à ne pas toucher les éléments chauffants situés à l'intérieur du

four. Les enfants de moins de 8 ans doivent être tenus à l'écart à moins qu'ils ne soient surveillés en permanence

— Cet appareil est conçu pour faire des cuissons porte fermée.

— Avant de procéder à un nettoyage pyrolyse de votre four, retirez tous les accessoires et enlevez les éclaboussures importantes.

— Dans la fonction de nettoyage, les surfaces peuvent devenir plus chaudes qu'en usage normal.

Il est recommandé d'éloigner les enfants.

— Ne pas utiliser d'appareil de nettoyage à la vapeur.

— Ne pas utiliser de produits d'entretien abrasifs ou de grattoirs métalliques durs pour nettoyer la porte en verre du four, ce qui pourrait érafler la surface et entraîner l'éclatement du verre.



**MISE EN GARDE :**

S'assurer que l'appareil est déconnecté de l'alimentation avant de remplacer la lampe pour éviter tout risque de choc électrique. Intervenez lorsque l'appareil est refroidi. Pour devisser le hublot et la lampe, utilisez un gant de caoutchouc qui facilitera le démontage.

## INSTRUCTIONS DE SECURITE

 La fiche de prise de courant doit être accessible après installation. Il doit être possible de déconnecter l'appareil du réseau d'alimentation, soit à l'aide d'une fiche de prise de courant, soit en incorporant un interrupteur dans les canalisations fixes conformément aux règles d'installation.

— Si le câble d'alimentation est endommagé, il doit être remplacé par le fabricant, son service après vente ou une personne de qualification similaire afin d'éviter un danger.

— Cet appareil peut être installé indifféremment sous plan ou en colonne comme indiqué sur le schéma d'installation.

— Centrez le four dans le meuble de façon à garantir une distance minimum de 10 mm avec le meuble voisin. La matière du meuble d'encastrement doit résister à la chaleur (ou être revêtu d'une telle matière). Pour plus de stabilité, fixez le four dans le meuble par 2 vis au travers des trous prévus à cet effet sur les montants latéraux.

— L'appareil ne doit pas être installé derrière une porte décorative, afin d'éviter une surchauffe.

— Cet appareil est destiné à être utilisé dans des applications domestiques et analogues telles que les coins cuisines réservés au personnel des magasins, bureaux et autres environnements profession-

nels; les fermes; l'utilisation par les clients des hôtels, motels et autres environnements à caractère résidentiel; les environnements de type chambre d'hôtes.

— Pour toute intervention de nettoyage dans la cavité du four, le four doit être arrêté.

Ne modifiez pas les caractéristiques de cet appareil, cela représenterait un danger pour vous.

Ne vous servez pas de votre four comme garde-manger ou pour stocker quelconques éléments après utilisation.

## 1



## Présentation du four

## 1.1 PRESENTATION DU FOUR

- A** Bandeau de commande
- B** Lampe
- C** Porte
- D** Poignée

Ce four dispose de 6 positions de gradins pour les accessoires: gradins de 1 à 6.

## 1.2 AFFICHAGE



- Durée de cuisson
- Fin de cuisson
- Verrouillage clavier
- Minuterie
- Indicateur de température
- Indicateur de préchauffage
- Verrouillage porte

## 1.3 TOUCHES

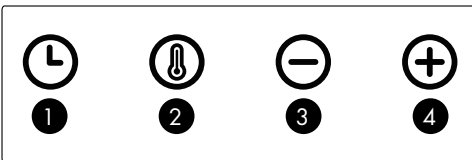

- 1** Réglage heure et durée
- 2** Réglage température
- 3** Touche -
- 4** Touche +

## 1.4 ACCESSOIRES (selon modèle)

**A • Grille sécurité anti-basculement**

La grille peut être utilisée pour supporter tous les plats et moules contenant des aliments à cuire ou à grater. Elle sera utilisée pour les grillades (à poser directement dessus).

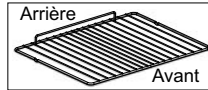

Insérer la grille, sécurité anti-basculement vers le fond du four.

**B • Plat multi usages lèche-frites 45mm**

Inséré dans les gradins sous la grille poignée vers la porte du four. Il recueille les jus et les graisses des grillades, il peut être utilisé à demi rempli d'eau pour des cuissons au bain-marie.

**C • Plat Pâtisserie 20mm**

Inséré dans les gradins poignée vers la porte du four. Idéal pour la cuisson de cookies, sablés, cupcake. Son pan incliné vous permet de déposer facilement vos préparations dans un plat. Peut aussi être inséré dans les gradins sous la grille, pour recueillir les jus et les graisses des grillades.

**Conseil**

**Afin d'éviter le dégagement de fumées durant la cuisson de viandes grasses, nous vous recommandons d'ajouter une faible quantité d'eau ou d'huile au fond de la lèche-frites.**

## 2



## Installation

## 2.1 CHOIX DE L'EMPLACEMENT ET ENCASTREMENT

Les schémas déterminent les côtes d'un meuble qui permettra de recevoir votre four.

Cet appareil peut être installé indifféremment sous plan **(A)** ou en colonne **(B)**. Si le meuble est ouvert, son ouverture doit être de 70 mm maximum à l'arrière. Fixez le four dans le meuble. Pour cela retirer les butées caoutchouc et pré-percez un trou de Ø 2 mm dans la paroi du meuble pour éviter l'éclatement du bois. Fixez le four avec les 2 vis. Remplacez les butées caoutchouc.

**Conseil**

**Pour être assuré d'avoir une installation conforme, n'hésitez pas à faire appel à un spécialiste de l'électroménager.**

**Attention**

**Avant d'utiliser votre four pour la première fois, chauffez-le à 200°C à vide pendant 1 heure environ. Assurez-vous que la pièce est suffisamment aérée.**

## RACCORDEMENT ELECTRIQUE

Le four doit être branché avec un câble d'alimentation normalisé à 3 conducteurs de 1,5 mm<sup>2</sup> ( 1 ph + 1 N + terre) qui doivent être raccordés sur le réseau 220~240 Volts par l'intermédiaire d'une prise de courant normalisée CEI 60083 ou d'un dispositif de coupure omnipolaire conformément aux règles d'installation.

Le fil de protection (vert-jaune) est relié à la borne ⊕ de l'appareil et doit être relié à la terre de l'installation. Le fusible de l'installation doit être de 16 ampères.

Notre responsabilité ne saurait être engagée en cas d'accident ou d'incident consécutif à une mise à la terre inexistante, défectueuse ou incorrecte ni en cas de branchement non conforme.

### ⚠ Attention :

**Si l'installation électrique de votre habitation nécessite une modification pour le branchement de votre appareil, faites appel à un électricien qualifié. Si le four présente une quelconque anomalie, débranchez l'appareil ou enlevez le fusible correspondant à la ligne de branchement du four.**

## 3 Mise à l'heure

### 3.1 MISE A L'HEURE

A la mise sous tension l'afficheur clignote à 12:00.

Réglez l'heure avec les touches + ou -.

Validez avec la touche ⊙

En cas de coupure de courant l'heure l'affichage clignote à 12:00.

### 3.2 MODIFICATION DE L'HEURE

Le sélecteur de fonction doit obligatoirement être sur la position 0.

Appuyez sur la touche ⊖ le symbole minuterie apparait ▲ appuyez de nouveau sur ⊖ ,ajustez le réglage de l'heure avec les touches + ou - .

Validez avec la touche ⊙.

### 3.3 MINUTERIE

**Cette fonction ne peut être utilisée que four à l'arrêt.**

Appuyez sur la touche ⊙.

La minuterie clignote.

Réglez la minuterie avec les touches + et -.

Appuyez sur la touche ⊙ pour valider, le compte à rebours se lance.



Une fois la durée écoulée, un signal sonore retentit.

Pour le stopper, appuyez sur n'importe quelle touche.

L'heure réapparaît dans l'afficheur.

NB:Vous avez la possibilité de modifier ou d'annuler la programmation de la minuterie à n'importe quel moment. Pour annuler retourner au menu de la minuterie et régler sur 00:00. Sans validation, l'enregistrement s'effectue automatiquement au bout de quelques secondes

## 3.4 VERROUILLAGE CLAVIER

Appuyez simultanément sur les touches + et - jusqu'à l'affichage du symbole  à l'écran. Pour le déverrouiller, appuyez simultanément sur les touches + et - jusqu'à ce que le symbole  disparaisse de l'écran.

## 4 Cuisson

### MODES DE CUISSON

(selon modèle)



#### CHALEUR TOURNANTE\*

Température mini 35°C maxi 235°C

Recommandé pour garder la moelleux des viandes blanches, poissons, légumes. Pour les cuissons multiples jusqu'à 3 niveaux.



#### TRADITIONNEL PULSE

Température mini 35°C maxi 275°C

Recommandé pour les viandes, poissons, légumes, posés dans un plat en terre de préférence.



#### GRIL PULSE

Température mini 180°C maxi 230°C

Volailles et rôtis juteux et croustillants sur toutes les faces.

Glissez la lèche-frites au gradin du bas.

Recommandé pour toutes les volailles ou rôtis, pour saisir et cuire à coeur gigots, côtes de boeuf. Pour garder leur fondant aux pavés de poissons.



#### SOLE PULSEE

Température mini 75°C maxi 250°C

Recommandé pour les plats humides (quiches, tartes aux fruits juteux...). La pâte sera bien cuite dessous. Recommandé pour les préparations qui lèvent (cake, brioche, kouglof...) et pour les soufflés qui ne seront pas bloqués par une croûte dessus.



#### TRADITIONNEL

Température mini 35°C maxi 275°C

Recommandé pour les cuissons lentes et délicates: gibiers moelleux. Pour saisir rôtis de viandes rouge.

## FRANÇAIS

Pour mijoter en cocotte fermée plats préalablement démarrés sur table de cuisson (coq au vin, civet).



### ECO\*

Température mini 35°C maxi 250°C

Cette position permet de faire un gain d'énergie tout en conservant les qualités de cuisson.

Toutes les cuissons se font sans préchauffage.



### GRIL FORT



### GRIL MOYEN

Température mini 180°C maxi 275°C

Recommandée pour griller des toasts, gratiner un plat, dorer une crème brûlée...



### MAINTIEN AU CHAUD

Température mini 35°C maxi 100°C

Recommandé pour faire lever les pâtes à pain, à brioche, kouglof.

Moule posé sur la sole, en ne dépassant pas 40°C (chauffe-assiette, décongélation).



### PIZZA

Température mini 35°C maxi 275°C

Effectuez un préchauffage puis enfournez au 3ème gradin.



### BOOST

Température mini 35°C maxi 275°C

Permet un préchauffage rapide de la cavité.

*\*Mode de cuisson réalisé selon les prescriptions de la norme EN 60350-1 : 2016 pour démontrer la conformité aux exigences d'étiquetage énergétique du règlement européen UE/65/2014.*



### Conseil économie d'énergie

En fonction  la lampe de la cavité s'éteint au bout de 90 secondes. Pendant la cuisson, gardez la porte du four fermée.

## 4.1 CUISSON IMMEDIATE

Le programmeur ne doit afficher que l'heure. Celle-ci ne doit pas clignoter.

Tournez le sélecteur de fonctions sur la position de votre choix.

La montée en température démarre immédiatement. Votre four vous préconise une température, modifiable.

Le four chauffe et l'indicateur de température clignote. Une série de bips sonores retentit lorsque le four atteint la température programmée.



## 4.2 MODIFICATION DE LA TEMPERATURE

Appuyez sur .

Ajustez la température avec + ou -.

Validez en appuyant sur .

## 4.3 PROGRAMMATION DE DURÉE

Effectuez une cuisson immédiate ensuite appuyez sur , la durée de cuisson  clignote, le réglage est alors possible. Appuyez sur + ou - pour régler la durée de cuisson.

Votre four est équipé de la fonction "SMART ASSIST" qui lors d'une programmation de durée, vous préconise une durée de cuisson modifiable selon le mode de cuisson choisi.

Voir le tableau ci-dessous:

FONCTION DE CUISSON (selon modèle)	PRÉCONISATION DE TEMPS
 TRADITIONNEL	30 min
 TRADITIONNEL PULSE	30 min
 CHALEUR TOURNANTE	30 min
 SOLE PULSE	30 min
 ECO	30 min
 GRIL MOYEN	10 min
 GRIL FORT	7 min
 GRIL PULSE	15 min
 MAINTIEN AU CHAUD	60 min
 PIZZA	15 min
 BOOST	5 min

L'enregistrement du temps de cuisson est automatique au bout de quelques secondes. Le décompte de la durée se fait immédiatement une fois la température de cuisson atteinte.

## 4.4 CUISSON DÉPART DIFFÉRÉ

Procédez comme une durée programmée. Après le réglage de la durée de cuisson, appuyez sur la touche . L'affichage clignote, réglez l'heure de fin de cuisson avec + ou -.

L'enregistrement de la fin de cuisson est automatique au bout de quelques secondes. L'affichage de la fin de cuisson ne clignote plus.

## 5



## Nettoyage

**NETTOYAGE DE LA SURFACE EXTERIEURE**

Utilisez un chiffon doux, imbibé de produit à vitre. N'utilisez pas de crèmes à récurer, ni d'éponge grattoir.

**NETTOYAGE DE L'INTERIEUR DU FOUR**

Nettoyez le four encore tiède avec un chiffon trempé dans de l'eau chaude savonneuse et essuyez avec un chiffon non pelucheux.

**5.1 DEMONTAGE DES GRADINS ET REMPLACEMENT DES PAROIS CATALYTIQUES****Parois latérales avec gradins fils :**

Soulevez la partie avant du gradin fils vers le haut poussez l'ensemble du gradin et faite sortir le crochet avant de son logement. Puis tirez légèrement l'ensemble du gradin vers vous afin de faire sortir les crochets arrière de leur logement. Retirez ainsi les 2 gradins et les parois catalytiques. Remplacez les nouveaux éléments (parois) en effectuant les opérations inverses.

**5.2 NETTOYAGE DE LA VITRE INTERIEURE**

Pour nettoyer la vitre intérieure démonter la porte. Avant le démontage enlevez avec un chiffon doux et du liquide vaisselle le surplus de graisse sur la glace intérieure.

**⚠ Mise en garde**

**Ne pas utiliser de produits d'entretien à récurer, d'éponge abrasive ou de grattoirs métalliques pour nettoyer la porte en verre du four, ce qui pourrait érafler la surface et entraîner l'éclatement du verre.**

**DÉMONTAGE**

Ouvrez complètement la porte et bloquez-la à l'aide de la cale plastique fournie dans la pochette plastique de votre appareil.

Retirez la glace clipée :

Appuyez à l'aide d'un outil (tournevis) dans les emplacements **A** afin de déclipper la glace.

Retirez la glace.

Ne pas immerger la glace dans l'eau. Rincez à l'eau claire et essuyez avec un chiffon non pelucheux.

**REMONTAGE DE LA PORTE**

Après nettoyage, repositionnez la glace et engagez-la dans les butées métallique, ensuite clippez-la, face brillante à l'extérieur.

Retirez la cale plastique.

Votre appareil est de nouveau opérationnel.

**5.3 REMPLACEMENT DE LA LAMPE****Caractéristiques de l'ampoule:**

15 W, 220-240 V~, 300°C, culot E14.

Pour dévisser le hublot et la lampe, utilisez un gant de caoutchouc qui facilitera le démontage.

**⚠ Mise en garde:**  
**Assurez-vous que l'appareil est déconnecté de l'alimentation avant de remplacer la lampe pour éviter tout risque de choc électrique. Intervenez lorsque l'appareil est refroidi.**

## 6

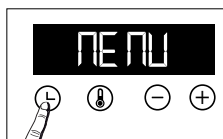

## Réglages

**6.1 MENU**

Vous pouvez intervenir sur différents paramètres de votre four, pour cela :

Appuyez sur la touche **⏪** jusqu'à l'affichage de **"MENU"** pour accéder au

mode de réglage. Appuyez de nouveau sur la touche **⏪** afin de faire défiler les différents réglages.

Activez ou désactivez avec les touches **+** et **-** les différents paramètres, voir tableau ci-dessous :

	Activez/désactivez les bips des touches
	Activez/désactivez le mode démonstration

Pour sortir du "MENU" appuyez de nouveau sur **⏪**.

## 7 ? Anomalies et solutions

**Le four ne chauffe pas.** Vérifiez si le four est bien branché ou si le fusible de votre installation n'est pas hors service. Augmentez la température sélectionnée.

**La lampe du four ne fonctionne pas.** Remplacez l'ampoule ou le fusible. Vérifiez si le four est bien branché.

**Le ventilateur de refroidissement continue de tourner à l'arrêt du four.** C'est normal, la ventilation peut fonctionner jusqu'à une heure maxi après la cuisson pour faire baisser la température intérieure et extérieure du four. Au-delà d'une heure, contactez le Service Après Vente.

## 8 Environnement

### RESPECT DE L'ENVIRONNEMENT

Les matériaux d'emballage de cet appareil sont recyclables. Participez à leur recyclage et contribuez ainsi à la protection de l'environnement en les déposant dans les conteneurs municipaux prévus à cet effet.



Votre appareil contient également de nombreux matériaux recyclables. Il est donc marqué de ce logo afin de vous indiquer que les appareils usagés ne doivent pas être mélangés avec d'autres déchets.

Le recyclage des appareils qu'organise votre fabricant sera ainsi réalisé dans les meilleures conditions, conformément à la directive européenne 2002/96/CE sur les déchets d'équipements électriques et électroniques.

Adressez-vous à votre mairie ou à votre revendeur pour connaître les points de collecte des appareils usagés les plus proches de votre domicile.

Nous vous remercions pour votre collaboration à la protection de l'environnement.

## 9 Service Après-Vente

### RELATIONS CONSOMMATEURS

Pour en savoir plus sur nos produits, vous pouvez consulter notre site :

[www.brandt.com](http://www.brandt.com)

vous pouvez nous contacter :

> Via notre site, [www.brandt.com](http://www.brandt.com) rubrique «SERVICES».

> Par e-mail à l'adresse suivante : [relations.consommateurs@groupebrandt.com](mailto:relations.consommateurs@groupebrandt.com)

> Par courrier à l'adresse postale suivante :

Service Consommateurs BRANDT

5, avenue des Béthunes

CS 69 526

95060 CERGY PONTOISE CEDEX

> Par téléphone du lundi au vendredi de 8h30 à 18h00 au :

**0 892 02 88 01**

Service 0,50 € / min  
+ prix appel

## INTERVENTIONS

Les éventuelles interventions sur votre appareil doivent être effectuées par un professionnel qualifié dépositaire de la marque. Lors de votre appel, afin de faciliter la prise en charge de votre demande, munissez-vous des références complètes de votre appareil (référence commerciale, référence service, numéro de série). Ces renseignements figurent sur la plaque signalétique.

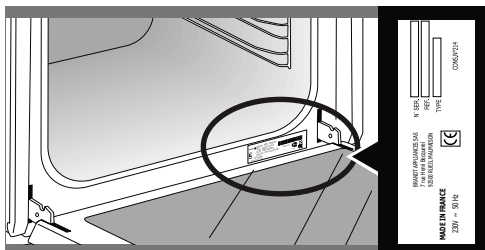

<b>A</b>	<b>B</b>	<b>G</b>
SERVICE: <b>C</b>	TYPE: <b>D</b>	
<b>E</b>	<b>F</b>	
Nr. <b>H</b>		<b>I</b>

B : Référence commerciale

C : Référence service

H : Numéro de série















Pour obtenir un rendez-vous avec un technicien, vous pouvez nous contacter du lundi au samedi de 8h00 à 20h00 au :















**09 69 39 25 25** Service gratuit  
+ prix appel

### PIÈCES D'ORIGINE

Lors d'une intervention d'entretien, demandez l'utilisation exclusive de **pièces détachées certifiées d'origine**.



PLATS	 *		 *		 *		 *		 *		 *		 *			
		NIVEAU		NIVEAU		NIVEAU		NIVEAU		NIVEAU		NIVEAU		NIVEAU	min	
<b>Viandes</b>																
Rôti de porc (1kg)	200	2					180	2								60
Rôti de veau (1kg)	200	2					180	2								60-70
Rôti de boeuf	240	2														30-40
Agneau (gigot, épaule 2,5 kg)	220	1			220						200	2				60
Volailles (1 kg)	200	2			220		180	2			210	3				60
Volailles grosses pièces	180	1														60-90
Cuisses de poulet					220	3					210	3				20-30
Côtes de porc / veau					210	3										20-30
Côtes de boeuf (1kg)					210	3					210	3				20-30
Côtes de mouton					210	3										20-30
<b>Poissons</b>																
Poissons grillés					275	4										15-20
Poissons cuisinés	200	3					180	3								30-35
Poissons papillottes	220	3					200	3								15-20
<b>Légumes</b>																
Gratins (aliments cuits)					275	2										30
Gratins dauphinois	200	2					180	2								45
Lasagnes	200	3					180	3								45
Tomates farcies	170	3					160	2								30
<b>Pâtisseries</b>																
Biscuit de Savoie - Génoise			180	2								180	2			35
Biscuit roulé	220	3										180	2			5-10
Brioche	180	1	210									180	2			35-45
Brownies	180	2					175	3								20-25
Cake - Quatre-quarts	180	1	180	1								180	2			45-50
Clafoutis	200	2					180	3								30-35
Crèmes	165	2										150	2			30-40
Cookies - Sablés	175	3														15-20
Kugelhopf			180	2								180	2			40-45
Meringues	100	2										100	3			60-70
Madeines	220	3					200	3								5-10

PLATS	 *		 *		 *		 *		 *		 *		 *			
		NIVEAU		NIVEAU		NIVEAU		NIVEAU		NIVEAU		NIVEAU		NIVEAU	min	
<b>Pâtisseries</b>																
Madeines	220	3					200	3								5-10
Pâtes à choux	200	3					180	3					180	3		30-40
Petits fours feuilletés	220	3					200	3								5-10
Savarin	180	3											175	3		30-35
Tarte pâte Brisée	200	1					195	1								30-40
Tarte pâte feuilletée fine	215	1					200	1								20-25
Tarte pâte à levure	210	1					200	1								10-30
<b>Divers</b>																
Brochettes	220	3			210	4										10-15
Pâté en terrine	200	2					190	2								80-100
Pizza pâte Brisée	200	2														30-40
Pizza pâte à pain																15-18
Quiches																35-40
Soufflé													180	2		50
Tourtes	200	2														40-45
Pain	220						200		220							30-40
Pain grillé	180				275	4-5										2-3
Cocottes fermées (daube)	180	2											180	2		90-180

\* Selon modèle

**Toutes les T°C et temps de cuisson sont donnés pour des fours préchauffés**

N.B: Avant d'être mises au four, toutes les viandes doivent rester au moins 1 heure à température ambiante.

**EQUIVALENCE : CHIFFRES  °C**

°C	30	60	90	120	150	180	210	240	275
<b>Chiffres</b>	<b>1</b>	<b>2</b>	<b>3</b>	<b>4</b>	<b>5</b>	<b>6</b>	<b>7</b>	<b>8</b>	<b>9 maxi</b>

## Recette avec levure (selon modèle)

Ingrédients:

● Farine 2 kg ● Eau 1240 ml ● Sel 40 g ● 4 paquets de levure de boulanger déshydratée

Mélanger la pâte avec le mixer et faire lever la pâte dans le four.





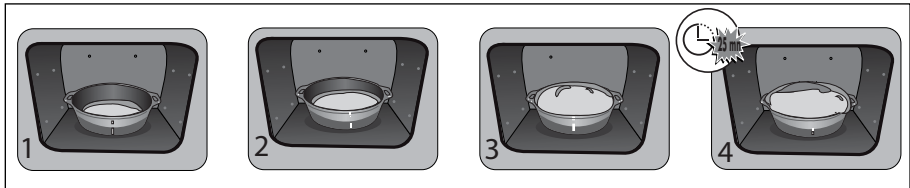













**Procédure:** Pour les recettes de pâtes à base de levure. Verser la pâte dans un plat résistant à la chaleur, retirer les supports de gradins fils et placer le plat sur la sole.

**Préchauffez le four avec la fonction chaleur tournante à 40-50 °C pendant 5 minutes. Arrêtez le four et laissez lever la pâte 25-30 minutes grâce à la chaleur résiduelle.**



## ESSAIS D'APTITUDE A LA FONCTION

### SELON LA NORME CEI 60350

ALIMENT	*Mode de cuisson	NIVEAU	Accessoires	°C	DUREE min.	PRECHAUF-FAGE
Sablés (8.4.1)		5	plat 45 mm	150	30-40	oui
Sablés (8.4.1)		5	plat 45 mm	150	25-35	oui
Sablés (8.4.1)		2 + 5	plat 45 mm + grille	150	25-45	oui
Sablés (8.4.1)		3	plat 45 mm	175	25-35	oui
Sablés (8.4.1)		2 + 5	plat 45 mm + grille	160	30-40	oui
Petits cakes (8.4.2)		5	plat 45 mm	170	25-35	oui
Petits cakes (8.4.2)		5	plat 45 mm	170	25-35	oui
Petits cakes (8.4.2)		2 + 5	plat 45 mm + grille	170	20-40	oui
Petits cakes (8.4.2)		3	plat 45 mm	170	25-35	oui
Petits cakes (8.4.2)		2 + 5	plat 45 mm + grille	170	25-35	oui
Gâteau moelleux sans matière grasse (8.5.1)		4	grille	150	30-40	oui
Gâteau moelleux sans matière grasse (8.5.1)		4	grille	150	30-40	oui
Gâteau moelleux sans matière grasse (8.5.1)		2 + 5	plat 45 mm + grille	150	30-40	oui
Gâteau moelleux sans matière grasse (8.5.1)		3	grille	150	30-40	oui
Gâteau moelleux sans matière grasse (8.5.1)		2 + 5	plat 45 mm + grille	150	30-40	oui
Tourte aux pommes (8.5.2)		1	grille	170	90-120	oui
Tourte aux pommes (8.5.2)		1	grille	170	90-120	oui
Tourte aux pommes (8.5.2)		3	grille	180	90-120	oui
Surface gratinée (9.2.2)		5	grille	275	3-6	oui

\* Selon modèle

**NOTA : Pour les cuissons à 2 niveaux, les plats peuvent être sortis à des temps différents.**



Dear Customer,

You have just acquired a **BRANDT** product and we would like to thank you.

We have designed and made this product with you, your lifestyle and your requirements in mind so that it meets your expectations. We have devoted our know-how, our innovative spirit and the passion that has been guiding us for over 60 years.

In an effort to ensure that our products meet your requirements in the best possible way, our Customer Relations department is at your disposal, to answer all your questions and to listen to all your suggestions.

Visit our website [www.brandt.com](http://www.brandt.com) where you will find our latest innovations, as well as useful and complementary information.

**BRANDT** is delighted to assist you every day and hopes you get the most out of your purchase.



**Important: Before using your appliance, read this user guide carefully to familiarise yourself more quickly with its operation.**

## SAFETY INSTRUCTIONS

### IMPORTANT SAFETY INSTRUCTIONS - READ CAREFULLY AND RETAIN FOR FUTURE USE.

This user guide is available for download on the brand's website.

When you receive the appliance, unpack it or have it unpacked immediately. Check its general appearance. Make a note of any reservations on the delivery slip and keep a copy.



#### Important:

This appliance may be used by children aged 8 years and older, and by persons with impaired physical sensorial or mental capacities, or without experience or knowledge, if they are supervised or have received prior instructions on how to use the appliance safely and have understood the risks involved. Children must not be allowed to play with the appliance. Cleaning and maintenance operations must not be carried out by children without supervision.

— Children must be supervised to prevent them from playing with the appliance.

#### WARNING:

— The appliance and its accessible parts become hot during use. Be careful not to touch the heating elements inside the oven. Children under 8 years old must not be allowed near it unless they are supervised at all times.

— This appliance is designed to cook with the door closed.

— Before pyrolytic cleaning of your oven, remove all accessories and any thick deposits.

— During cleaning, the surfaces may become warmer than under normal conditions of use. It is advisable to keep children away from the appliance.

— Do not use a steam cleaner.

— Do not use abrasive cleaning products or hard metal scrapers for cleaning the oven's glass door, as they could scratch the surface and cause the glass to shatter.



#### WARNING :

Make sure the appliance is disconnected from the power before replacing the lamp in order to avoid the risk of electric shock. Change the lamp only when the appliance has cooled down. To unscrew the view port and the light, use a rubber glove, which will make disassembly easier.

## SAFETY INSTRUCTIONS

 The electrical plug must remain accessible after installation.

— It must be possible to disconnect the appliance from the power supply, either using a plug or by fitting a switch on the fixed wiring system in accordance with installation rules.

— If the power cable is damaged, it should be replaced by the manufacturer, its after-sales service department or by a similarly qualified person in order to avoid danger.

— This appliance may be installed either under a worktop or in a cabinet column, as indicated on the installation diagram.

— Centre the oven in the unit so as to ensure a minimum distance of 10 mm between the appliance and the surrounding unit. The material of the unit supporting the appliance must be heat-resistant (or covered with a heat-resistant material). For greater stability, attach the oven to the unit with 2 screws through the holes provided on the side panels.

— In order to avoid overheating, the appliance must not be installed behind a decorative door.

— This appliance is designed to be used for domestic and similar applications such as:

Kitchen areas for the staff of shops, offices and other professional premises; Farms; Use by clients of hotels, motels and other residential

type establishments; guest house type environments.

— The oven must be turned off when cleaning inside the oven.

Do not modify the characteristics of this appliance; doing so could be dangerous.

Do not use your oven as a larder or to store any items after use.

# 1 Description of the oven

## 1.1 PRESENTATION OF THE OVEN

- A** Control panel
- B** Light
- C** Door
- D** Handle

This oven has 6 positions for the accessories: shelf supports 1 to 6.

## 1.2 DISPLAY



- Cooking time
- End of cooking
- Keypad lock
- Timer
- Temperature indicator
- Pre-heating indicator
- Door lock

## 1.3 BUTTONS

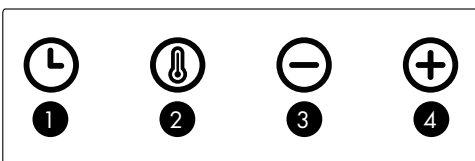

- 1** Set clock and cooking time
- 2** Set temperature
- 3** - button
- 4** + button

## 1.4 ACCESSORIES (depending on model)

### A • Anti-tip safety grid

The grid can be used to hold all dishes and moulds containing foodstuffs to be cooked or browned. It can be used for barbecues (to be placed directly on the grid).

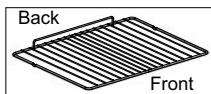

Insert the anti-tip safety grid towards the back of the oven.

### B • Multi-purpose 45mm drip pan

When inserted in the supports under the grid with the handle towards the oven door, it collects juice and fat from grilling, and can be used half-filled with water as a double-boiler.

### C • 20mm pastry dish

When inserted in the supports with the handle towards the oven door, it is ideal for baking cookies, shortbread and cupcakes. Its tilted surface makes it practical and easy to use. Can also be inserted into the supports under the grid to collect juice and fat from grilling.



**To avoid fumes when cooking fatty meats, we recommend you add a small amount of water or oil to the bottom of the drip pan.**

# 2 Installation

## 2.1 CHOICE OF LOCATION AND FITTING

The diagrams show the dimensions of a cabinet that will be able to hold your oven.

This appliance may be installed either under a worktop (**A**) or in a column (**B**). If the cabinet is open, its opening at the back must be 70 mm maximum.

Install the oven in the furniture. To do this, remove the rubber stops and pre-drill a 2-mm diameter hole in the wall of the furniture to avoid splitting the wood. Attach the oven with the two screws. Re-position the rubber stops.



**To be certain that you have properly installed your appliance, do not hesitate to call on a household appliance specialist.**

### ⚠ Caution

**Before using your oven for the first time, heat it to 200°C empty for around 1 hour. Ensure that the room is sufficiently aired.**

## ELECTRICAL CONNECTION

Your oven must be connected with a (standard) power cable with 3 conductors of 1.5mm<sup>2</sup> (1 live + 1 neutral + earth) which must be connected to a 220-240V, ~ single-phase grid by means of a 1 live + 1 neutral + earth CEI 60083 standard power socket or via an all-poles cut-off device in compliance with the installation rules.

The safety wire (green-yellow) is connected to the appliance's Ⓢ terminal and must be connected to the earth terminal of the electrical set-up.

The fuse in your set-up must be 16 amperes.

We cannot be held responsible for any accident resulting from in-existent, defective or incorrect earthing.



### Warning :

***If the electrical installation in your residence requires any changes in order to hook up your appliance, contact a professional electrician. If the oven malfunctions in any way, unplug the appliance or remove the fuse corresponding to the sector where the oven is hooked up.***

## 3



### Setting the clock

### 3.1 SETTING THE CLOCK

When switching on the display flashes at 12:00. Set the clock with + or -.

Confirm with ⏻.

If there is a power cut, the clock flashes at 12:00.

### 3.2 CHANGING THE CLOCK

The function selector switch must be in the 0 position.

Press ⏻. The symbol 🕒 appears. Press ⏻ again, adjust the clock setting with + or -.

Confirm with ⏻.

The cooking end time is automatically saved after a few seconds.

### 3.3 TIMER

**This function can only be used when the oven is off.**

Press ⏻.

The timer flashes.

Set the timer with + or -.

Press ⏻ to confirm. The timer will then start.

Once the time has lapsed, there is a sound signal. To stop it, press any key.

The time appears again in the display.

NB: You can modify or cancel the timer at any time. To cancel, go back to the timer menu and set to 00:00. Without having to confirm, the adjustment is automatically saved after a few seconds.

## 3.4 KEYPAD LOCKING

Press + and - at the same time until the 🔒 symbol appears on the screen. To unlock the keypad, press + and - together until the 🔒 symbol disappears off the screen.

## 4



### Cooking

### COOKING MODES

(depending on model)



#### CIRCULATING HEAT\*

Min temperature 35°C, max 235°C

Recommended for keeping white meat, fish and vegetables moist. For cooking multiple items on up to three levels.



#### TRADITIONAL PULSE

Min temperature 35°C, max 275°C

Recommended for quiches, pies, tarts with juicy fruits, preferably in an earthenware dish.



#### GRILL PULSE

Min temperature 180°C, max 230°C

Roasts and poultry are juicy and crisp all over. Slide the drip tray on to the bottom shelf support. Recommended for all spit-roasted poultry or meat, for sealing and thoroughly cooking a leg or a rib of beef. To retain the moist texture of fish steaks.



#### PULSED BOTTOM

Min temperature 75°C, max 250°C

Recommended for moist dishes (quiches, tarts with juicy fruits, etc.). The pastry will be thoroughly cooked on the bottom. Recommended for recipes which rise (cake, brioche, kügelhopf, etc.) and for soufflés which will not be stopped by a crust on the top.



#### TRADITIONAL

Min temperature 35°C, max 275°C

Recommended for slow, gentle cooking: rich game, etc. For retaining the juices in red meat roasts. For simmering in a covered casserole, dishes that were begun on the hob (coq au vin, stew).



Min temperature 35°C, max 250°C  
This setting saves energy while maintaining the quality of the cooking.  
All types of cooking are done without preheating.



Min temperature 180°C, max 275°C  
Recommended for toast, gratin dishes, browning crème brûlée, etc.



Min temperature 35°C, max 100°C  
Recommended for letting dough rise for bread, brioche, kügelhopf.  
Put the mould on the bottom, not exceeding 40°C (plate-warming, defrosting).



Min temperature 35°C, max 275°C  
Pre-heat and then put in the oven on the 3rd shelf support.



Min temperature 35°C, max 275°C  
To rapidly pre-heat the oven.

*\*Cooking mode as per standard EN 60350-1: 2016 to demonstrate compliance with requirements of the energy label of European regulation UE/65/2014.*

**Advice on how to save energy**  
**Keep the oven door closed during cooking.**

## 4.1 IMMEDIATE COOKING

The programmer must only display the time. It should not be flashing.  
Turn the function selector to any position.  
The temperature starts to increase at once. Your oven suggests a temperature, which can be modified.  
The oven heats up and the temperature indicator flashes. A series of beeps sounds when the oven has reached the programmed temperature.

## 4.2 CHANGING THE TEMPERATURE

Press .  
Adjust the temperature with + or -.  
Confirm by pressing .

## 4.3 PROGRAMMING THE COOKING TIME

Use the immediate cooking programme, then press ; the cooking time flashes and it is now possible to set it. Press + and - to adjust the cooking time.  
Your oven has the "SMART ASSIST" function which, when programming a cooking time, will suggest a cooking time which can be modified depending on the selected cooking mode.  
See the table opposite:

COOKING FUNCTION (depending on model)	COOKING TIME RECOMMENDATION
TRADITIONAL	30 min
TRADITIONAL PULSE	30 min
CIRCULATING HEAT	30 min
PULSED BOTTOM	30 min
ECO	30 min
MEDIUM GRILL	10 min
FULL GRILL	7 min
GRILL PULSE	15 min
KEEP WARM	60 min
PIZZA	15 min
BOOST	5 min

The cooking time is saved automatically after a few seconds. The time starts to count down as soon as the cooking temperature is reached.

## 4.4 DELAYED START

Proceed as for programmed cooking. After setting the cooking time, press ; the cooking end time flashes.  
The display flashes. Set the cooking end time with

+ and - .

The cooking end time is automatically saved after a few seconds. The cooking end time display stops flashing.

## 5 Cleaning

### CLEANING THE OUTER SURFACES

Use a window washing product applied to a soft cloth. Do not use abrasive creams or scouring sponges.

### CLEANING INSIDE THE OVEN

Clean the still-warm oven with a cloth dipped in hot, soapy water and wipe with a lint-free cloth.

## 5.1 REMOVING THE SHELF SUPPORTS AND REPLACING THE CATALYTIC SIDE PANELS

### Side panels with wire shelf supports :

Lift the front part of the wire shelf support upwards. Press the entire shelf support and release the front hook from its housing. Then gently pull the whole of the support towards you to release the rear hooks from their housing. Remove the two shelf supports and **the catalytic side panels. Re-install the new elements (side panels) following the procedure in reverse.**

## 5.2 CLEANING THE INSIDE GLASS

To clean the inside glass, remove the door. Before doing this, remove any excess grease with a soft cloth and washing up liquid.

### Warning

**Do not use scouring cleaning products, abrasive sponges or metal scrapers to clean the oven's glass door, which may scratch the surface and lead to the glass breaking.**

### REMOVAL

Open the door fully and block it with the plastic wedge provided in your appliance's plastic pouch.

Remove the first clipped glass panel:

Use a tool (screwdriver) to press the slots  in order to unclip the glass panel.

Remove the glass panel.

Depending on the model, the door consists of two

additional glass panels, with a black rubber spacer at each corner. If necessary, remove them to clean. Do not soak the glass panels in water. Rinse with clean water and dry off with a lint-free cloth.

### RE-ASSEMBLING THE DOOR

After cleaning, reposition the four rubber stops with the arrow upwards.

Reposition all of the glass panels.

Slip the last glass panel into the metal stops, then clip it in with the shiny side facing outwards.

Remove the plastic wedge.

Your appliance is now ready for use again.

## 5.3 REPLACING THE OVEN LAMP

### Warning:

**Make sure the appliance is disconnected from the power before replacing the lamp in order to avoid the risk of electric shock. Change the lamp only when the appliance has cooled down.**

### Bulb specification:

15 W, 220-240 V~, 300°C, E14 cap.

To unscrew the view port and the light, use a rubber glove, which will make disassembly easier.

## 6 Settings

### 6.1 MENU

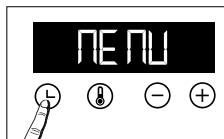



You can adjust different settings on your oven. To do so:

Press  until you get to the "MENU" display to access the settings mode.

Press  again to scroll through the different settings.

Activate or de-activate the different parameters with + and -; see table below:

	Activate/de-activate the beeping sound of the buttons
	Activate/de-activate demonstration mode

To exit the "MENU", press  again.

## 7 ? Anomalies and solutions

You may resolve certain little problems yourself:

**The oven is not heating.** Check that the oven is correctly connected and that your installation's fuse is not out of service. Increase the selected temperature.

**The oven light is not working.** Replace the bulb or the fuse. Check that the oven is correctly connected.

**The cooling fan continues to operate after the oven stops.** This is normal; the fan may continue running until a maximum of 1 hour after cooking to lower the temperature inside and outside the oven. If the fan runs for over an hour, contact the After Sales Department.

## 8 Environment

### CARE FOR THE ENVIRONMENT

- This appliance's packing materials are recyclable. Please recycle them and help protect the environment by depositing them in municipal containers provided for this purpose.



- Your appliance also contains many recyclable materials. It is therefore marked with this logo to indicate that used appliances must not be mixed with other waste.

The appliance recycling organised by your manufacturer will therefore be conducted in optimum conditions, in accordance with European directive 2002/96/EC on electrical and electronic equipment waste.

Consult your local authority or your retailer to locate your nearest used appliance drop-off points.

- We thank you for your help in protecting the environment.

## 9 Service Calls

### SERVICE CALLS

Any repairs made to your appliance must be carried out by a qualified professional authorised to work on the brand. When calling, please provide the complete references of your appliance (commercial reference, service reference, serial number), so that we can handle your call better. This information appears on the manufacturer's nameplate attached to your equipment.

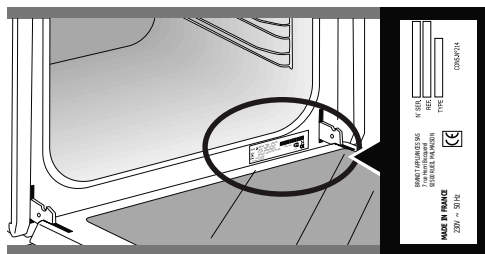

	<b>A</b>	<b>B</b>	<b>G</b>
SERVICE:	<b>C</b>	TYPE:	<b>D</b>
	<b>E</b>	<b>F</b>	
Nr.	<b>H</b>		<b>I</b>

B: Commercial reference

C: Service reference

H: Serial number















### GENUINE REPLACEMENT PARTS

During maintenance work, request that only **certified genuine replacement parts** are used.



DISHES	 *		 *		 *		 *		 *		 *		 *			
	LEVEL	LEVEL	LEVEL	LEVEL	LEVEL	LEVEL	LEVEL	LEVEL	LEVEL	LEVEL	LEVEL	LEVEL	LEVEL	LEVEL	min	
<b>Meat</b>																
Roast pork (1kg)	200	2					180	2								60
Roast veal (1kg)	200	2					180	2								60-70
Roast beef	240	2														30-40
Lamb (leg, shoulder, 2.5kg)	220	1			220						200	2				60
Poultry (1kg)	200	2			220		180	2			210	3				60
Large pieces of poultry	180	1														60-90
Chicken thighs					220	3					210	3				20-30
Pork/veal chops					210	3										20-30
Beef ribs (1kg)					210	3					210	3				20-30
Lamb chops					210	3										20-30
<b>Fish</b>																
Grilled fish					275	4										15-20
Cooked fish (bream)	200	3					180	3								30-35
Fish in papillote	220	3					200	3								15-20
<b>Vegetables</b>																
Gratins (cooked foods)					275	2										30
Potato gratin	200	2					180	2								45
Lasagne	200	3					180	3								45
Stuffed tomatoes	170	3					160	2								30
<b>Pastries</b>																
Sponge cake			180	2									180	2		35
Swiss roll	220	3											180	2		5-10
Buns	180	1	210										180	2		35-45
Brownies	180	2					175	3								20-25
Cake - Pound cake	180	1	180	1									180	2		45-50
Clafoutis	200	2					180	3								30-35
Baked custards	165	2											150	2		30-40
Cookies - Shortbread	175	3														15-20
Kugelhoppf			180	2									180	2		40-45
Meringues	100	2											100	3		60-70
Madeleines	220	3					200	3								5-10

\* Depending on the model

DISHES	 *		 *		 *		 *		 *		 *		 *			
		LEVEL		LEVEL		LEVEL		LEVEL		LEVEL		LEVEL		LEVEL	min	
<b>Pastries</b>																
Madeleines	220	3					200	3								5-10
Choux pastry	200	3					180	3					180	3		30-40
Flaky pastry hors d'oeuvres	220	3					200	3								5-10
Savarin cake	180	3											175	3		30-35
Shortcrust tart	200	1					195	1								30-40
Thin flaky crust tart	215	1					200	1								20-25
Tart made with yeast-based	210	1					200	1								10-30
<b>Other</b>																
Skewers	220	3			210	4										10-15
Terrine pâté	200	2					190	2								80-100
Shortcrust pizza	200	2														30-40
Dough-based pizza																15-18
Quiches																35-40
Soufflé													180	2		50
Pies	200	2														40-45
Bread	220						200		220							30-40
Bread	180				275	4-5										2-3
Casseroles (stews)	180	2											180	2		90-180

\* Depending on the model



**All °C and cooking times are given for pre-heated ovens.**

N.B: Before being placed in the oven , all meat must remain at least 1 hour at room temperature.

RELATIONSHIP OF SETTINGS TO TEMPERATURE  °F / °C									
Setting	1	2	3	4	5	6	7	8	9 maxi
° Fahrenheit	85	140	195	250	300	355	410	465	525
° Celsius	30	60	90	120	150	180	210	240	275

## Recipe with yeast (depending on model)

Ingredients:

● Flour 2 kg ● Water 1240 ml ● Salt 40 g ● 4 packets of dehydrated baker's yeast

Mix the dough in a mixer and allow to rise in the oven.

**Method:** For yeast-based pastry recipes. Pour the dough into a heat-resistant dish. Remove the wire shelf supports and put the dish on the bottom.

**Pre-heat the oven to 40–50°C with the circulating heat function for five minutes. Stop the oven and allow the dough to rise for 25-30 minutes thanks to the residual heat.**

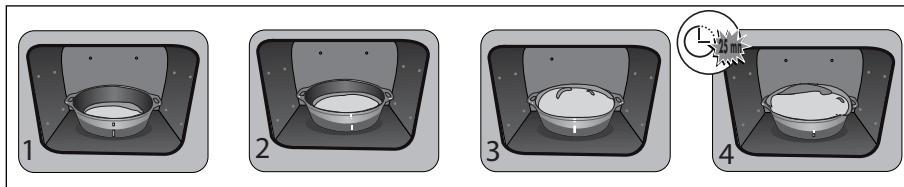

## PERFORMANCE TESTING ACCORDING TO STANDARD CEI 60350

FOOD	* Cooking modes	SHELF	ACCESSORIES	°C	TIME min.	PREHEAT
Shortbread (8.4.1)		5	Deep Tray 45mn	150	30-40	yes
Shortbread (8.4.1)		5	Deep Tray 45mn	150	25-35	yes
Shortbread (8.4.1)		2 + 5	Deep Tray 45mn + grill	150	25-45	yes
Shortbread (8.4.1)		3	Deep Tray 45mn	175	25-35	yes
Shortbread (8.4.1)		s	Deep Tray 45mn + grill	160	30-40	yes
Small cakes (8.4.2)		5	Deep Tray 45mn	170	25-35	yes
Small cakes (8.4.2)		5	Deep Tray 45mn	170	25-35	yes
Small cakes (8.4.2)		2 + 5	Deep Tray 45mn + grill	170	20-40	yes
Small cakes (8.4.2)		3	Deep Tray 45mn	170	25-35	yes
Small cakes (8.4.2)		2 + 5	Deep Tray 45mn + grill	170	25-35	yes
Fatless sponge cake (8.5.1)		4	Grill	150	30-40	yes
Fatless sponge cake (8.5.1)		4	Grill	150	30-40	yes
Fatless sponge cake (8.5.1)		2 + 5	Deep Tray 45mn + grill	150	30-40	yes
Fatless sponge cake (8.5.1)		3	Grill	150	30-40	yes
Fatless sponge cake (8.5.1)		2 + 5	Deep Tray 45mn + grill	150	30-40	yes
Apple pie (8.5.2)		1	Grill	170	90-120	yes
Apple pie (8.5.2)		1	Grill	170	90-120	yes
Apple pie (8.5.2)		3	Grill	180	90-120	yes
Surface browning (9.2.2)		5	Grill	275	3-6	yes

\* Depending on the model

N.B. : To cook on 2 levels, dishes can be taken out at different times.





Geachte klant,

U heeft zojuist een **BRANDT** gekocht; wij danken u dan ook voor uw vertrouwen in onze producten.

We hebben dit product ontworpen en geproduceerd met uzelf, uw levenswijze en uw noden in ons achterhoofd om ervoor te zorgen dat het zo goed mogelijk aan uw verwachtingen voldoet. U vindt er onze knowhow, onze innoveringsgeest en alle passie in terug die ons al meer dan 60 jaar drijft.

Aangezien we er voortdurend naar streven zo goed mogelijk te beantwoorden aan uw eisen, staat onze klantendienst geheel te uwer beschikking en biedt ze u een luisterend oor voor al uw vragen of suggesties.

Kijk ook op onze site **[www.brandt.com](http://www.brandt.com)** daar vindt u al onze producten en nuttige en aanvullende informatie.

**BRANDT** is verheugd om u dagelijks te begeleiden en wenst u heel veel plezier met uw aankoop.



**Belangrijk: Alvorens uw apparaat aan te zetten, lees eerst aandachtig deze installatie- en gebruikshandleiding zodat u sneller vertrouwd bent met de werking ervan**

## VEILIGHEIDSINSTRUCTIES

### BELANGRIJKE VEILIGHEIDSINSTRUCTIES - LEES ZE AANDACHTIG EN BEWAAR ZE VOOR TOEKOMSTIG GEBRUIK.

U kunt deze handleiding downloaden op de website van het merk.



Pak na ontvangst het toestel uit of laat dit onmiddellijk uitpakken. Controleer het algemeen aanzicht. Laat eventuele opmerkingen noteren op de vrachtbrief waarvan u een kopie bewaart.

#### Belangrijk:

Dit apparaat mag worden gebruikt door kinderen vanaf 8 jaar, en door personen met lichamelijke, sensorische of geestelijke beperkingen of door personen zonder ervaring en kennis, als ze onder toezicht staan of vooraf instructies gekregen hebben over hoe ze het apparaat veilig moeten gebruiken, en begrepen hebben aan welke risico's ze zich blootstellen.

— Kinderen mogen niet met het apparaat spelen. Schoonmaak en gebruikersonderhoud mogen niet worden uitgevoerd door kinderen zonder toezicht

— Laat kinderen nooit onbewaakt, om te vermijden dat ze met het apparaat zouden spelen.

#### WAARSCHUWING:

— Het apparaat en de bereikbare onderdelen worden warm tijdens het gebruik. Wees voorzichtig de verwarmingselementen binnen in de oven niet aan te raken. Kinderen jonger dan 8 moeten worden weggehouden tenzij ze onder permanent toezicht staan

— Dit apparaat is ontworpen voor gebruik met gesloten deur.

— Voordat u een pyrolyserreiniging van uw oven uitvoert, moet u eerst alle accessoires en de belangrijkste vlekken verwijderen.

— In de reinigungsmodus kunnen de oppervlakken warmer worden dan tijdens het normale gebruik.

Het is raadzaam om kinderen weg te houden.

— Gebruik geen stoomreiniger.

— Geen schuurmiddelen of harde metalen krabbers gebruiken om de glazen deur van de oven schoon te maken. Deze kunnen krassen op het oppervlak en breuk van het glas veroorzaken.



#### LET OP :

Verzeker u ervan dat het apparaat van het elektriciteitsnet is afgekoppeld voordat u de lamp vervangt, om elk elektrocutiegevaar te vermijden. Wacht tot het apparaat afgekoeld is. Gebruik een rubberen

## VEILIGHEIDSINSTRUCTIES

handschoen om het losschroeven van het vensterkapje en het lampje te vereenvoudigen.

 Het stopcontact moet na de installatie goed bereikbaar zijn. Het apparaat moet van het elektriciteitsnet kunnen worden afgekoppeld, door middel van een stekker in het stopcontact of door een schakelaar te installeren op de vaste voedingsleidingen, volgens de installatieregels.

— Indien de voedingskabel is beschadigd, moet deze door de fabrikant, de klantenservice of een ander gekwalificeerd persoon veiligheidshalve worden vervangen.

— Dit apparaat kan zowel onder het werkblad als in een inbouwkast worden geïnstalleerd, zoals te zien is op het installatieschema.

— Centreer de oven in het meubel en bewaar daarbij een afstand van minstens 10 mm tot het meubel ernaast. Het materiaal van het inbouwmeubel moet warmtebestendig zijn (of bekleed zijn met dergelijk materiaal). Bevestig de oven voor meer stabiliteit in het meubel met behulp van 2 schroeven door de daartoe voorziene gaten.

— Het apparaat mag niet achter een decoratieve deur worden geplaatst, om oververhitting te

voorkomen.

— Dit apparaat is bestemd voor huishoudelijk en vergelijkbaar gebruik, zoals: keukenhoeken voor het personeel in magazijnen, kantoren en andere beroepsomgevingen; boerderijen, gebruik door klanten van hotels, motels en andere woonomgevingen; omgevingen zoals bed and breakfasts.

— Voor alle reiniging van de oven, moet de oven uitgeschakeld zijn.

Wijzig de eigenschappen van dit apparaat niet, dit kan gevaarlijk voor u zijn.

Gebruik uw oven niet als voorraadkast of opslag na gebruik.

# 1 Voorstelling van de oven







## 1.1 VOORSTELLING VAN DE OVEN

- A** Bedieningspaneel
- B** Lamp
- C** Deur
- D** Handgreep

Deze oven heeft 6 niveaus voor de accessoires: niveau 1 t/m 6.

## 1.2 WEERGAVE



-  Baktijd
-  Einde baktijd
-  Vergrendeling toetsenbord
-  Timer
-  Temperatuurindicator
-  Indicator voorverwarming
-  Deurvergrendeling

## 1.3 TOETSEN

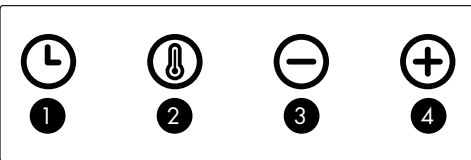

- 1** Instelling van tijd en duur
- 2** Instelling temperatuur
- 3** Toets -
- 4** Toets +

## 1.4 ACCESSOIRES (volgens het model)

### A • Rooster met kantelbeveiliging

Het rooster kan gebruikt worden om alle borden en vormen met te bakken of te gratineren voedingswaren op te zetten. Het zal voor gegrilde gerechten gebruikt worden (die er rechtstreeks op mogen staan).

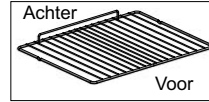

Plaats het rooster met de kantelbeveiliging naar de bodem van de oven gericht.

### B • Plaat voor multigebruik met lekbak 45 mm

Geplaatst in de roosterinkepingen met de handgreep naar de ovendeur gericht. Deze dient om sap en vet van gegrilde gerechten op te vangen en kan half met water gevuld worden voor de bain-marie bereidingen.

### C • Patisserieplaat 20 mm

Geplaatst in de inkepingen met de handgreep naar de ovendeur gericht. Ideaal voor het bakken van cookies, zandkoekjes, cupcakes. Met de schuine zijde kunt u eenvoudig uw bereidingen op een schaal leggen. Kan ook in de roosterinkepingen geplaatst worden om het bakvocht en vet van gegrilde gerechten op te vangen.

### Advies

**Om tijdens het bakken van vet vlees rookontwikkeling te vermijden, raden wij u aan een klein beetje water of olie in de lekbak te schenken.**

# 2 Installatie

## 2.1 KEUZE VAN DE PLAATSING EN INBOUW

De schema's bepalen de afmetingen van een meubel waarin uw oven past.

Dit toestel kan zonder onderscheid onder een werkvlak (**A**) of in kolom (**B**), geplaatst worden. Als de behuizing open is, mag de opening aan de achterzijde maximaal 70 mm zijn.

Maak de oven vast in het meubel. Verwijder hiervoor de rubber blokjes en boor een gat van Ø 2 mm voor in de wand van het meubel om te voorkomen dat het hout barst. Maak de oven met 2 schroeven vast. Zet de rubber blokjes terug.



**Advies**  
Om er zeker van te zijn dat u een conforme installatie heeft, doet u best een beroep op een specialist in huishoudtoestellen.



**Opgelet**  
Voordat u de oven voor de eerste keer gebruikt, warmt u deze leeg op gedurende ongeveer 1 uur op 200°C. Zorg ervoor dat de ruimte goed geventileerd is.

Uw oven moet aangesloten worden met een voedingskabel (genormaliseerd) met 3 geleiders van 1,5 mm<sup>2</sup> (1f + 1N + aarding) die aangesloten worden op het elektriciteitsnet van 220-240V~, monofasig via een genormaliseerd stopcontact 1f + 1 neutraal + aarding overeenkomstig de norm CEI 60083 of een omnipolaire schakelaar of overeenkomstig de installatievoorschriften.

De beschermingsdraad (groen-geel) is verbonden met de aansluitklem  van het apparaat en moet worden verbonden met de aarding van de installatie. De zekering van uw installatie moet 16 ampère zijn. Het is noodzakelijk het voedingsnetwerk te kunnen uitschakelen na de installatie.



**Let op**  
De uitschakeling wordt bekomen door een toegankelijke stroomkabel te voorzien of door een schakelaar te plaatsen op de vaste leiding die voldoet aan de installatieregels.

## 3



Inschakeling van de tijd

### 3.1 INSCHAKELING VAN DE TIJD



Bij het opstarten knippert het scherm op 12:00. Stel de tijd in met de toetsen + of -.

Bevestig met de toets .

BIJ EEN STROOMONDERBREKING KNIPPERT DE WEERGAVE VAN DE TIJD.

### 3.2 WIJZIGING VAN DE TIJD

De functiekeuzeknop moet verplicht op de stand 0 staan.

Druk op de toets  het symbool  verschijnt druk opnieuw op . Verander de instelling van de tijd met de toetsen + of -.

Bevestig met de toets .

Het registreren van de veranderde tijd gaat automatisch, na enkele seconden.

## 3.3 TIMER

Deze functie kan alleen gebruikt worden wanneer de oven uit staat.

Druk op de toets .

Het symbool knippert.

Stel de timer in met de toetsen + en -.



Druk op de toets  om te bevestigen, het aftellen begint.

Wanneer de tijd verstreken is, klinkt er een geluidssignaal. Om dit te stoppen, drukt u op een willekeurige toets.

De tijd verschijnt opnieuw op het display.

NB: Het is mogelijk om op elk gewenst moment de timerprogrammering te wijzigen of te annuleren. Ga voor het annuleren terug naar het menu van de timer en stel deze af op 00:00. Zonder bevestiging vindt het registreren automatisch na enkele seconden plaats.

## 3.4 VERGREDELING TOETSENBOARD

Druk tegelijkertijd op de toetsen + en - totdat het symbool  wordt weergegeven op het scherm. Druk voor het ontgrendelen tegelijkertijd op de toetsen + en - totdat het symbool  van het scherm verdwijnt.

## 4



Bakken

**BAKWIJZEN** (afhankelijk van het model)



**HETELUCHTFUNCTIE\***

Temperatuur, min. 35°C, max. 235°C

Aanbevolen voor om wit vlees, vis en groenten mals te houden. Voor meerdere bakbeurten tot 3 niveaus.



**TRADITIONELE PULS**

Temperatuur, min. 35°C, max. 275°C

Aanbevolen voor vlees, vis, groenten, bij voorkeur in een aarden schotel.



**GRILL PULS**

Temperatuur, min. 100°C, max. 250°C

Gevogelte en rollade zijn sappig en krokant gebakken aan alle kanten.

Schuif de lekbak in het onderste niveau.

Aanbevolen voor alle gevogelte en gebrad, om lam aan te braden en goed uit te bakken, runderrribben.

Om vissteaks sappig te houden.



### GEPUKSTE BODEM

Temperatuur, min. 75°C, max. 250°C

Aanbevolen voor vochtige gerechten (quiches, taart van sappig fruit, enz.). Het deeg wordt onderaan goed gebakken. Aanbevolen voor bereidingen die rijzen (cake, brioche, kouglof (tulbandgebak)...) en soufflés die niet worden geblokkeerd door een korst aan de bovenzijde.



### TRADITIONEEL

Temperatuur, min. 35°C, max. 275°C

Aanbevolen voor langzaam, zacht bakken: zacht wild. Om rollade van rood vlees aan te braden. Voor het laten sudderen van gesloten ovenschalen die eerder zijn gestart op de kookplaat (coq au vin, stoofpot).



### ECO\*

Temperatuur, min. 35°C, max. 275°C

Met deze positie wordt energie bespaard terwijl de kookkwaliteiten behouden blijven.

Alle bakwijzen gebeuren zonder voorverwarmen.



### KRACHTIGE GRILL

Temperatuur, min. 180°C, max. 275°C

Aanbevolen om toast te roosteren, gerechten te gratineren, crème brûlée van een goudbruin korstje te voorzien...



### MIDDELHOGE GRILL



### WARM HOUDEN

Temperatuur, min. 35°C, max. 100°C

Aanbevolen voor het doen rijzen van brood-, brioche-, kouglofdeeg, ontdooien of schotels warm te houden.



### PIZZA

Temperatuur, min. 35°C, max. 275°C

Voor een gegarandeerd resultaat de pizza op het 3e niveau in de voorverwarmde oven plaatsen.



### BOOST

Temperatuur, min. 35°C, max. 275°C

Om de temperatuur in de ovenruimte snel te doen stijgen.



**Tip voor energiebesparing**  
90 seconden nadat de deur werd gesloten of het koken is begonnen, gaat het lampje binnen in de oven uit.

## 4.1 ONMIDDELIJK BAKKEN

Het display mag enkel het uur weergeven. Het mag niet knipperen.

Zet de functieschakelaar op de gewenste stand.

De temperatuur begint onmiddellijk te stijgen.

Uw oven beveelt een temperatuur aan, die u kunt veranderen.

De oven verwarmt en de temperatuurindicator knippert. Een reeks geluidssignalen weerklinkt wanneer de oven de geprogrammeerde temperatuur bereikt.

## 4.2 WIJZIGING VAN DE TEMPERatuur

Druk op .

Stel de temperatuur bij met + of -.







Bevestig door op  te drukken.

## 4.3 PROGRAMMERING VAN DE TIJDSDUUR



Begin onmiddellijk met bakken en druk daarna op , de weergave van de baktijd knippert, instellen is dan mogelijk. Druk op + of - om de baktijd in te stellen.

Uw oven is voorzien van de functie "SMART ASSIST" die tijdens het programmeren van de tijdsduur u een veranderbare baktijd aanbeveelt aan de hand van de gekozen bakwijze.

Zie onderstaande tabel:

BAK- FUNCTIE (afhankelijk van het model)	AANBEVOLEN TIJDEN
 TRADITIONEEL	30 min
 TRADITIONELE PULS	30 min
 HETELUCHTFUNCTIE	30 min
 GEPUKSTE BODEM	30 min
 ECO	30 min
 MIDDELHOGE GRILL	10 min
 KRACHTIGE GRILL	7 min
 GRILL PULS	15 min

\*Bakwijze volgens de aanbevelingen van de norm EN 60350-1: 2016 om aan te tonen dat wordt voldaan aan de eisen van de Europese verordening EU/65/2014 inzake energie-etiketten.

BAK- FUNCTIE (afhankelijk van het model)	AANBEVOLEN TIJ- DEN
 <b>WARM HOUDEN</b>	60 min
 <b>PIZZA</b>	15 min
 <b>BOOST</b>	5 min

De registratie van de kooktijd gebeurt automatisch in een paar seconden. Het aftellen van de tijdsduur begint zodra de baktemperatuur bereikt is.

#### 4.4 BAKKEN MET UITGESTELDE START

Procedure zoals bij de geprogrammeerde tijdsduur. Druk na het instellen van de baktijd op de toets , de tijd van het einde van het bakken knippert.

De weergave knippert, stel de tijd van het einde van de baktijd in met + of -.

De registratie van het einde van de baktijd gebeurt automatisch in een paar seconden. Het display met kookeinde stopt met knippen.

## 5 Reiniging

### REINIGEN VAN HET BUITENOPPERVLAK

Gebruik een zachte, vochtige doek met glasreiniger. Gebruik geen schuurmiddelen noch harde sponzen.

### 5.1 DEMONTAGE VAN DE NIVEAUHOUDERS

Til het voorste gedeelte van de houder op en duw tegen het geheel, zodat de voorste haak uit zijn zitting komt. Trek vervolgens de hele houder naar u toe, zodat de achterste haken uit hun zitting komen. Verwijder zo de 2 houders.

### 5.2 REINIGING VAN DE BINNENKANT VAN DE RUITEN

Demonteer de deur om de binnenzijde van het glas te reinigen. Verwijder voor het demonteren met een zachte doek en afwasmiddel de vetvlekken aan de binnenkant van het glas.

 **Let op**  
Geen schuurmiddelen, schuursponzen of metalen krabbers gebruiken om de glazen deur van de oven schoon te maken. Deze kunnen krassen op het oppervlak en breuk van het glas veroorzaken.

### DEMONTAGE

Open de deur volledig en blokkeer deze met de in het plastic zakje met uw apparaat meegeleverde wig van rood plastic.

Verwijder het eerste vastgeklikte glas:

Druk met behulp van gereedschap (schroevendraaier) in de plaatsen **A** om het glas los te klikken.

Verwijder het glas.

Afhankelijk van het model bestaat de deur uit twee extra glazen platen met in iedere hoek een vulstuk van zwart rubber. Verwijder deze, indien nodig, om ze te reinigen.

Dompel het glas niet in water onder. Spoel met water, veeg droog met een niet pluizende doek.

### MONTAGE VAN DE DEUR

Zet na het reinigen de vier rubber blokjes terug met de pijl naar boven en zet alle glazen platen weer terug.

Plaats het laatste glas in de metalen blokjes, klik dit vervolgens vast met de glanzende zijde naar buiten gericht.

Verwijder de wig van rood plastic.

Uw toestel is opnieuw operationeel.

## 5.4 HET VERVANGEN VAN DE LAMP.

 **Let op**  
Zorg ervoor dat het apparaat is losgekoppeld van het stopcontact voordat u de lamp vervangt om het risico van een elektrische schok te voorkomen. Voer werkzaamheden uit wanneer het apparaat is afgekoeld.

**Eigenschappen van de gloeilamp:** 15 W, 220-240 V~, 300°C, voet E14.

Gebruik om het venster en de lamp los te schroeven, een rubberen handschoen, die de demontage zal vergemakkelijken.

## 6 Instellingen

### 6.1 MENU

U kunt diverse parameters van uw oven zelf instellen, ga daarvoor als volgt te werk:

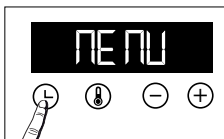

Druk op de toets  tot dat "MENU" wordt weergegeven, om toegang te krijgen tot de instellingen-

modus. Druk opnieuw op de toets om de verschillende instellingen door te lopen. Schakel met de toetsen met + en - de verschillende parameters in of uit, zie onderstaande tabel:

	De pieptonen van de toetsen in-/uitschakelen
	De voorverwarmingsmodus in-/uitschakelen

Druk voor het verlaten van het "MENU" opnieuw op .

# 8



## Milieu

### RESPECT VOOR HET MILIEU

Het verpakkingsmateriaal van dit apparaat is recyclebaar. Doe mee aan de recycling en draag bij aan de bescherming van het milieu door dit materiaal in de hiervoor bestemde gemeentecontainers te deponeren.



Uw apparaat bevat eveneens tal van recyclebare materialen. Daarom is het voorzien van dit logo wat aangeeft dat de gebruikte apparaten van ander afval  dienen te worden gescheiden.

De recyclage van de apparaten die door uw fabrikant wordt georganiseerd, wordt op deze manier onder de beste omstandigheden uitgevoerd, overeenkomstig de Europese richtlijn 2002/96/CE betreffende elektrisch en elektronisch afval.

Informeer bij uw gemeente of bij uw verkoper naar de dichtstbijzijnde inzamelplaats voor uw oude apparaten.

Wij danken u voor uw bijdrage aan de bescherming van het milieu.

# 7



## Storingen en oplossing

**De oven wordt niet warm.** Zorg ervoor dat de oven goed is aangesloten en controleer of de elektrische zekering niet is uitgeslagen. Verhoog de gekozen temperatuur.

**De ovenverlichting werkt niet.** Vervang de lamp of zekering. Zorg ervoor dat de oven correct is aangesloten.

**De koelventilator blijft aan na het uitschakelen van de oven.** Dat is normaal, de ventilatie kan tot max. een uur na het bakken werken om de temperatuur binnen en buiten de oven te laten zakken. Bij langer dan een uur, contact opnemen met de servicedienst.

**De pyrolyse reiniging wordt niet uitgevoerd.** Controleer de sluiting van de deur. Als er een storing op de deurvergrendeling of temperatuursensor optreedt, bel de servicedienst.

**Het symbol  knippert op het display.** Deurslot defect, bel de servicedienst.

# 9



## Interventies

### INTERVENTIES

Eventuele interventies aan uw toestel moeten worden uitgevoerd door een gekwalificeerde professionele technicus van het merk. Om bij het opbellen de verwerking van uw verzoek te vergemakkelijken, houdt de volledige referentie van uw toestel bij de hand (commerciële referentie, servicereferentie, serienummer). Deze informatie wordt weergegeven op het identificatieplaatje.

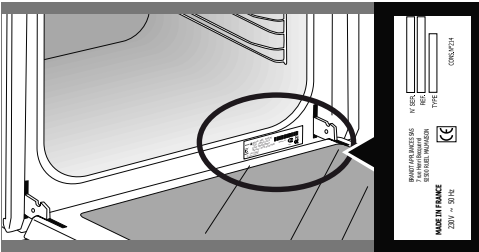

A		B		
SERVICE :	C	TYPE :	D	E
	F			
Nr.	H			I

- B : Commerciële referentie
- C : Servicereferentie
- H : Serienummer

GERECHTEN	 *		 *		 *		 *		 *		 *		 *			
		Inschuifbaar		Inschuifbaar		Inschuifbaar		Inschuifbaar		Inschuifbaar		Inschuifbaar		Inschuifbaar	min	
<b>Vlees</b>																
Varkensgebraad (1kg)	200	2					180	2								60
Kalfsgebraad (1kg)	200	2					180	2								60-70
Rundergebraad	240	2														30-40
Lamsvlees (bout, schouder 2,5 kg)	220	1			220						200	2				60
Gevogelte (1 kg)	200	2			220		180	2			210	3				60
Gevogelte, groot formaat	180	1														60-90
Kippenbouten					220	3					210	3				20-30
Varkens- / kalfsrib					210	3										20-30
Runderribben (1kg)					210	3					210	3				20-30
Schaapsribben					210	3										20-30
<b>Vis</b>																
Geroosterde vis					275	4										15-20
Gebakken vis (goudbrasem)	200	3					180	3								30-35
Vis in folie	220	3					200	3								15-20
<b>Groenten</b>																
Gegratineerde schotels (gare)					275	2										30
Gratins dauphinois	200	2					180	2								45
Lasagne	200	3					180	3								45
Gevulde tomaten	170	3					160	2								30
<b>Gebak</b>																
Sponscake - Luchtige cake			180	2								180	2			35
Opgerolde cake	220	3										180	2			5-10
Brioche	180	1	210									180	2			35-45
Brownies	180	2					175	3								20-25
Cake - Evenveeltje	180	1	180	1								180	2			45-50
Kersenvlaai	200	2					180	3								30-35
Crèmes	165	2										150	2			30-40
Cookies - Zandkoekjes	175	3														15-20
Kugelhopf			180	2								180	2			40-45
Schuimgebak	100	2										100	3			60-70
Madeleines	220	3					200	3								5-10

\* volgens model

GERECHTEN	*		*		*		*		*		*		*		*		
		Inschufluur		Inschufluur		Inschufluur		Inschufluur		Inschufluur		Inschufluur		Inschufluur		Inschufluur	min
<b>Gebak</b>																	
Madeleines	220	3					200	3									5-10
Soezendeeg	200	3					180	3						180	3		30-40
Kleine bladerdeeghapjes	220	3					200	3									5-10
Savarin	180	3												175	3		30-35
Taart van kruimeldeeg	200	1					195	1									30-40
Taart van fijn bladerdeeg	215	1					200	1									20-25
Taart van gistdeeg	210	1					200	1									10-30
<b>Diversen</b>																	
Spiesen	220	3			210	4											10-15
Pastei	200	2					190	2									80-100
Pizza van kruimeldeeg	200	2															30-40
Pizza van brooddeeg																	15-18
Quiches																	35-40
Soufflé														180	2		50
Taart met deegdeksel	200	2															40-45
Brood	220						200		220								30-40
Geroosterd brood	180				275	4-5											2-3
Stoofgerechten	180	2												180	2		90-180

\* volgens model



Oven voorverwarmen tot de vermelde temperatuur.

Laat alle vlees minstens 1 uur op kamertemperatuur staan alvorens het in de oven te plaatsen.

THERMOSTAAT : CIJFER MET OVEREENSTEMMENDE GRADENWAARDE IN  °C									
°C	30	60	90	120	150	180	210	240	275
CIJFER	1	2	3	4	5	6	7	8	9 maxi

## Recept met gist (afhankelijk van het model)

Ingrediënten:

• Bloem 2 kg • Water 1240 ml • Zout 40 g • 4 zakjes gedroogd bakpoeder

Meng het deeg met de mixer en laat het in de oven rijzen.

**Procedure:** Voor recepten van deeg met gist. Leg het deeg in een ovenvaste schaal, verwijder de niveauhouders en zet de schaal op de ovenbodem.

**Verwarm de oven op de heteluchtfunctie voor op 40-50 °C gedurende 5 minuten. Schakel de oven uit en laat het deeg 25-30 minuten in de nog warme oven rijzen.**

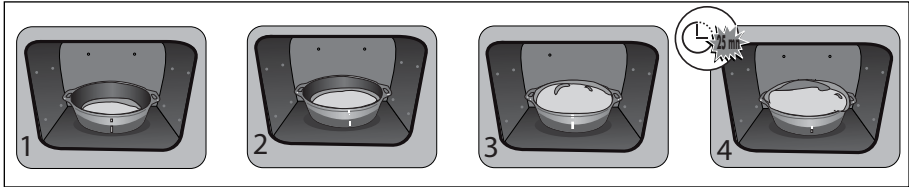

## KEURINGSTESTS VOLGENS NORM IEC 60350

VOEDINGSMIDDEL	Bakwijzen	RICHEL	OPMERKINGEN	°C	TIJD	VOORVERWARMING
Zandkoekjes (8.4.1)		5	Plaat 45mn	150	30-40	JA
Zandkoekjes (8.4.1)		5	Plaat 45mn	150	25-35	JA
Zandkoekjes (8.4.1)		2 + 5	Plaat 45mn + Rooster	150	25-45	JA
Zandkoekjes (8.4.1)		3	Plaat 45mn	175	25-35	JA
Zandkoekjes (8.4.1)		2 + 5	Plaat 45mn + Rooster	160	30-40	JA
Cakejes (8.4.2)		5	Plaat 45mn	170	25-35	JA
Cakejes (8.4.2)		5	Plaat 45mn	170	25-35	JA
Cakejes (8.4.2)		2 + 5	Plaat 45mn + Rooster	170	20-40	JA
Cakejes (8.4.2)		3	Plaat 45mn	170	25-35	JA
Cakejes (8.4.2)		2 + 5	Plaat 45mn + Rooster	170	25-35	JA
Zachte taart zonder vet (8.5.1)		4	Rooster	150	30-40	JA
Zachte taart zonder vet (8.5.1)		4	Rooster	150	30-40	JA
Zachte taart zonder vet (8.5.1)		2 + 5	Plaat 45mn + Rooster	150	30-40	JA
Zachte taart zonder vet (8.5.1)		3	Rooster	150	30-40	JA
Zachte taart zonder vet (8.5.1)		2 + 5	Plaat 45mn + Rooster	150	30-40	JA
Appeltaart (8.5.2)		1	Rooster	170	90-120	JA
Appeltaart (8.5.2)		1	Rooster	170	90-120	JA
Appeltaart (8.5.2)		3	Rooster	180	90-120	JA
Gegratineerde bovenzijde (9.2.2)		5	Rooster	275	3-6	JA

\* volgens model

**LET OP: Wanneer u bakt op 2 niveaus kunnen de bereidingen op verschillende tijdstippen uit de oven gehaald worden.**



Liebe Kundin, lieber Kunde,

Sie haben soeben ein **BRANDT** Produkt erworben, und wir danken Ihnen für Ihr Vertrauen.

Wir haben bei der Planung und Herstellung dieses Produktes an Sie gedacht, an Ihren Lebensstil, an Ihre Bedürfnisse, damit es ihren Erwartungen bestmöglich entspricht. In diesem Produkt steckt unser Know-how, unser Innovationsgeist und die ganze Leidenschaft, die uns seit mehr als 60 Jahren antreibt.

Wir sind stets darum bemüht, Ihre Anforderungen immer besser zu erfüllen. Unser Verbraucherservice steht Ihnen daher selbstverständlich immer zur Verfügung und geht auf alle Ihre Fragen und Anregungen ein.

Besuchen Sie auch unsere Website [www.brandt.com](http://www.brandt.com). Sie finden dort eine Übersicht über unsere neuesten Innovationen, sowie weitere nützliche Hinweise.

**BRANDT** ist geehrt, Sie im Alltag zu begleiten, und wünscht Ihnen viel Freude mit Ihrem neuen Produkt.



**Wichtig: Bitte lesen Sie die vorliegenden Hinweise zu Installation und Gebrauch vor der ersten Inbetriebnahme aufmerksam durch, damit Sie Ihr Gerät schnell beherrschen.**

## SICHERHEITSHINWEISE

### WICHTIGE SICHERHEITSHINWEISE - AUFMERKSAM LESEN UND FÜR SPÄTERE NUTZUNG AUFBEWAHREN.

Diese Anleitung ist auf der Internetpräsenz der Marke zum Download verfügbar.

Das Gerät bei Lieferung sofort auspacken oder auspacken lassen. Sein allgemeines Aussehen prüfen. Vermerken Sie eventuelle Vorbehalte schriftlich auf dem Lieferschein und behalten Sie ein Exemplar davon.



**Wichtig:**

Dieses Gerät kann von Kindern ab einem Alter von 8 Jahren, von Personen mit körperlich, sensorisch oder geistig eingeschränkten Fähigkeiten oder von Personen ohne Erfahrung oder Kenntnis verwendet werden, wenn sie beaufsichtigt oder in die Gerätebenutzung eingewiesen worden sind, auch was die Sicherheit betrifft, und wenn sie die damit verbundenen Risiken verstanden haben.

— Kinder dürfen nicht mit dem Gerät spielen. Beim Reinigen und Pflegen dürfen Kinder nicht unbeaufsichtigt bleiben.

— Kinder müssen beaufsichtigt werden, damit sie nicht mit dem Gerät spielen.

**WARNUNG:**

— Das Gerät und seine zugänglichen Teile werden bei der Benutzung heiß. Die Heizelemente im Backofen nicht berühren. Kinder in einem Alter von weniger als 8 Jahren müssen vom Gerät ferngehalten werden, sofern sie nicht ständig überwacht werden.

— Dieses Gerät ist für das Garen bei geschlossener Tür bestimmt.

— Vor der Reinigung des Backofens durch Pyrolyse nehmen Sie bitte alles Zubehör heraus und entfernen Sie größere Spritzer.

— Während des Reinigungsvorgangs können die Oberflächen heißer werden als bei normalem Gebrauch.

Es ist empfohlen, Kinder fernzuhalten.

— Keinen Dampfreiniger verwenden.

— Für das Reinigen der Glastür des Backofens dürfen keine Scheuermittel oder Metallschaber verwendet werden, da durch ihre Verwendung Kratzer auf der Oberfläche oder Sprünge im Glas verursacht werden könnten.



**WARNUNG:**

Vor Austausch der Lampe sicherstellen, dass die Stromzufuhr abgeschaltet ist, um jegliche Gefahr eines Stromschlags zu vermeiden. Warten, bis das Gerät abgekühlt ist. Zum leichteren Herausdrehen der Lampenabdeckung einen Gummihandschuh verwenden.



Der Netzstecker muss nach der Installation zugänglich sein. Es muss möglich sein, das Gerät vom Stromnetz abzuschalten, entweder durch Ziehen des Netzsteckers, oder durch Einbauen eines Schalters in die fest installierten Leitungen gemäß den

## SICHERHEITSHINWEISE

Installationsanweisungen.

— Ein beschädigtes Netzkabel muss vom Hersteller, dessen Kundendienst oder einer fachgerecht qualifizierten Person ausgetauscht werden, um jeglicher Gefahr vorzubeugen.

— Dieses Gerät kann gemäß Einbauanleitung beliebig unter einer Arbeitsplatte installiert oder in einen Hochschrank eingebaut werden.

— Den Backofen mittig in das Möbel einbauen, so dass ein Mindestabstand von 10 mm zum benachbarten Möbel gewährleistet wird. Das Material des Einbaumöbels muss hitzebeständig sein (oder es muss mit einem hitzebeständigen Material beschichtet sein). Für eine höhere Stabilität den Backofen mit 2 Schrauben in den vorgesehenen Löchern an den Seitenträgern befestigen.

— Das Gerät darf nicht hinter einer Dekorationstür installiert werden, um Überhitzung zu vermeiden.

— Dieses Gerät ist für Haushaltsanwendungen und ähnliche Anwendungen bestimmt wie beispielsweise: Teeküchen für Mitarbeiter von Ladengeschäften, Büros und anderen Arbeitsumfeldern. Landwirtschaftliche Betriebe. Verwendung durch Gäste von Hotels, Motels und anderen Unterkunftszwecken dienenden Einrichtungen.

— Den Garraum nur bei abgeschaltetem Ofen reinigen.

Die Gerätemerkmale dürfen nicht verändert werden, dies würde für Sie eine Gefahr darstellen.

Benutzen Sie den Ofen nach Nutzung nicht als Vorratskammer oder zur Aufbewahrung von Gegenständen.

## 1



## BESCHREIBUNG DES OFENS

## 1.1 ÜBERSICHT ÜBER DEN BACKOFEN

- A Bedienleiste
- B Lampe
- C Tür
- D Griff

Dieser Backofen verfügt über 6 Einschubleistenpositionen für das Zubehör: Einschubleisten 1 bis 6.

## 1.2 ANZEIGE



- 🔔 Garzeit
- 🕒 Ende des Garvorgangs
- 🔒 Verriegelung der Tasten
- 🕒 Zeitschaltuhr
- °C Temperaturanzeige
- ➡➡ Vorheizanzeige
- 🔑 Verriegelung der Tür

## 1.3 TASTEN

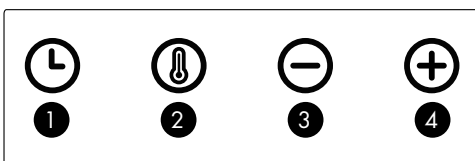

- 1 Einstellung der Uhrzeit und Dauer
- 2 Einstellung der Temperatur
- 3 Taste -
- 4 Taste +

## 1.4 ZUBEHÖR (je nach Modell)

## A • Rost mit Kippschutz

Das Rost ist für jede Art von Kochgeschirr und Kuchenform zum Kochen oder Überbacken geeignet. Er wird für Grillgerichte benutzt (sie werden direkt auf den Rost gelegt).

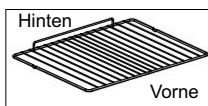

Das Rost mit dem Kippschutz nach hinten in

den Ofen einschieben.

## B • Mehrzweck-Fettpfanne 45mm

Sie wird in die unter dem Rost befindlichen Einschubleisten mit dem Griff zur Ofentürseite eingeschoben. Sie fängt Bratensaft und Fett des Grillgutes auf. Zum Garen im Wasserbad kann sie zur Hälfte mit Wasser gefüllt werden.

## C • Kuchenblech 20mm

Sie wird in die Einschubleisten mit dem Griff zur Ofentürseite eingeschoben. Ideal für das Backen von Keksen, Mürbegebäck, Cupcakes. Mit seiner schräg abgewinkelten Fläche können Sie Ihr Backgut leicht in einer Schüssel ablegen. Kann auch in die unter dem Rost befindlichen Einschubleisten eingeschoben werden, um den Bratensaft und das Fett des Grillgutes aufzufangen.

## 🔍 Empfehlung

**Um die Rauchbildung beim Garen von fettreichem Fleisch zu vermeiden, empfehlen wir Ihnen, eine kleine Menge an Wasser oder Öl auf dem Boden der Fettpfanne hinzuzufügen.**

## 2



## Installation

## 2.1 WAHL DES AUFSTELLUNGSRORTS UND EINBAU

Aus den Abbildungen gehen die Maße eines Möbels hervor, in den der Ofen eingesetzt werden kann.

Dieses Gerät kann ebenso gut unter einer Arbeitsplatte (A) wie in Säulenaufstellung (B) installiert werden. Bei einem offenen Möbel muss die Öffnung hinten maximal 70 mm groß sein.

Befestigen Sie den Backofen im Möbel. Dafür die Distanzstücke aus Gummi entfernen und in die Möbelwand ein Loch von 2 mm Durchmesser bohren, um ein Reißen des Holzes zu verhindern. Den Backofen mit den 2 Schrauben befestigen. Setzen Sie die Distanzstücke aus Gummi wieder ein.

## 🔍 Empfehlung

**Lassen Sie Ihre Installation von einem Fachmann für Haushaltsgeräte die fachgerechte Installation bestätigen.**

**Achtung**

**Vor der ersten Nutzung des Ofens, diesen leer auf 200°C etwa 1 Stunde lang aufheizen. Vergewissern Sie sich, dass der Raum ausreichend belüftet ist.**

**ELEKTRISCHER ANSCHLUSS**

Der Herd muss mit einem (genormten) Stromkabel mit 3 Leitern mit 1,5 mm<sup>2</sup> Leitungsquerschnitt (1 Ph 1 N + Erdung) angeschlossen werden, die an das 220 - 240 V ~ Netz über eine Steckdose nach IEC Norm 60083 oder eine omnipolare Stromunterbrechung gemäß den Installationsregeln angeschlossen sein müssen.

Das Schutzkabel (grün-gelb) ist an den Erdungsanschluss ⊕ des Gerätes angeschlossen und muss geerdet werden. Die Anlage erfordert eine 16 Ampere-Sicherung.

Wir übernehmen keine Haftung für Unfälle oder Vorkommnisse aufgrund nicht vorhandener, defekter oder nicht ordnungsgemäßer Erdung oder von nicht normgerechtem Anschluss.

**Achtung:**

**Wenn die Stromanlage der Wohnung für den Anschluss des Geräts geändert werden muss, wenden Sie sich bitte an einen qualifizierten Elektriker. Wenn der Ofen irgendeine Störung aufweist, das Gerät vom Netz trennen oder die Sicherung für die Anschlussleitung des Geräts herausnehmen.**

**3****Einstellung der Uhrzeit****3.1 EINSTELLUNG DER UHRZEIT**

Beim Einschalten des Stroms blinkt die Anzeige auf 12:00.

Stellen Sie die Zeit mit den Tasten + oder - ein.

Mit der Taste ⏻ BESTÄTIGEN.

Bei Stromausfall blinkt die Uhrzeit.

**3.2 ÄNDERUNG DER UHRZEIT**

Der Schalter für die Funktionswahl muss auf 0 stehen. Drücken Sie die Taste ⏻ das Symbol ⚡ erscheint drücken Sie erneut auf ⏻. Stellen Sie die Zeit mit den Tasten + oder - ein.

Mit der Taste ⏻ BESTÄTIGEN.

Die gewünschte Uhrzeit wird automatisch nach einigen Sekunden abgespeichert.

**3.3 ZEITSCHALTUHR**

**Diese Funktion kann nur benutzt werden, wenn der Ofen ausgeschaltet ist.**

Drücken Sie auf die Taste ⏻.

Die Zeitschaltuhr blinkt.

Stellen Sie die Zeitschaltuhr mit den Tasten + und - ein. Drücken Sie die Taste ⏻ um zu bestätigen, die Rückwärtszählung beginnt.

Wenn die eingestellte Zeit abgelaufen ist, ertönt ein Signalton. Um ihn zu stoppen, drücken Sie eine beliebige Taste.

Die Zeit erscheint erneut in der Anzeige.

Hinweis: Sie können die Programmierung der Zeitschaltuhr jederzeit ändern oder annullieren. Zum Löschen zum Menü der Zeitschaltuhr zurückkehren und auf 00:00 einstellen. Ohne Bestätigung geschieht die Registrierung nach einigen Sekunden automatisch.

**3.4 VERRIEGELUNG DER TASTEN**

Drücken Sie gleichzeitig die Tasten + und - bis zur Anzeige des Symbols 🔒 auf dem Bildschirm. Um zu entsperren, drücken Sie gleichzeitig die Tasten + und -, bis das Symbol 🔒 vom Bildschirm verschwindet.

**4****Garen****GARMETHODEN** (je nach Modell)**UMLUFT\***

Temperatur min. 35°C max. 235°C

Empfohlen für zartes helles Fleisch, Fisch und Gemüse. Für gleichzeitige Gar- und Backvorgänge auf bis zu 3 Ebenen.

**HERKÖMMLICH/GEPULTE****FUNKTIONEN\***

Temperatur min. 35°C max. 275°C

Empfohlen für Fleisch, Fisch, Gemüse, die vorzugsweise in einem irdenen Gefäß gegart werden.

**GEPULTE GRILLFUNKTION**

Temperatur min. 180°C max. 250°C

Für saftige(s), rundum knusprige(s) Geflügel und Braten.

Die Fettpfanne in die untere Einschubleiste einschieben.

Für alle Geflügelsorten oder Braten zum Anbraten und Garen von Lammkeule, Rinderkoteletts empfohlen. Zur Erhaltung des zarten Charakters von Fischkoteletts.

**GEPULTE HERBODENFUNKTION**

Temperatur min. 75°C max. 250°C

Empfohlen für Backgut mit hohem Feuchtigkeitsgehalt (Quiches, saftige Obstkuchen...). Der Teig wird unten knuspriger. Empfohlen für Backgut mit beim Backen

weiter aufgehendem Teig (Kastenkuchen, Hefenapf Kuchen, Gugelhupf usw.) und für Soufflés, die so nicht durch eine sich obenauf bildende Kruste gebremst werden.



### HERKÖMLICH

Temperatur min. 35°C max. 275°C

Für langsame und empfindliche Garvorgänge empfohlen: weich gegartes Wildbret. Zum Anbraten von dunklem Fleisch. Zum Schmoren im geschlossenen Kochtopf nach der Vorbereitung auf dem Kochfeld (Hähnchen in Rotweinsauce, Hasenpfeffer).



### ECO\*

Temperatur min. 35°C max. 275°C

Mit dieser Einstellung kann bei gleich guten Garergebnissen Energie gespart werden.

Alle Garvorgänge erfolgen ohne Vorwärmen.



### GRILL STARK



### GRILL MITTEL

Temperatur min. 180°C max. 275°C

Empfohlen, um Toasts zu grillen, ein Gericht zu überbacken, eine Crème brûlée zu bräunen ...



### WARMHALTEN

Temperatur min. 35°C max. 100°C

Empfohlen für das Aufgehen von Brot-, Hefe-, Gugelhupfteig, das Abtauen oder Telleraufwärmen.



### PIZZA

Temperatur min. 35°C max. 275°C

Um ein gutes Gelingen Ihrer Pizzen zu garantieren, schieben Sie sie bei heißem Ofen in die Einschubhöhe 3.



### BOOST

Temperatur min. 35°C max. 275°C

Ermöglicht einen schnellen Temperaturanstieg im Garraum

*\*Garvorgang entsprechend der Vorschriften der Norm EN 60350-1: 2016, als Nachweis der Konformität mit der Energieeffizienzzeichnung der europäischen Verordnung UE/65/2014.*



### Energiespar-Tipp

Wenn die Funktion  aktiviert ist, erlischt die Lampe im Garraum nach 90 Sekunden. Halten Sie während des Garens die Ofentür geschlossen.

## 4.1 SOFORTIGES GAREN

Die Programmiervorrichtung darf nur die Uhrzeit anzeigen. Sie darf nicht blinken.

Drehen Sie den Funktionswahlschalter auf die Position Ihrer Wahl.

Der Temperaturanstieg startet sofort. Ihr Backofen empfiehlt Ihnen eine Temperatur, die Sie jedoch ändern können.

Der Backofen heizt auf und die Temperatur-Anzeige blinkt. Bei Erreichen der eingestellten Backofentemperatur ertönt eine Reihe von Lautsignalen.



## 4.2 ÄNDERUNG DER TEMPERATUR

Drücken Sie auf .

Regeln Sie die Temperatur mit + oder -.

Durch Drücken auf  bestätigen.

## 4.3 PROGRAMMIERUNG DER DAUER



Führen Sie einen sofortigen Garvorgang durch und drücken Sie anschließend auf , die Garzeit  blinkt, die Einstellung ist dann möglich. Drücken Sie auf + oder -, um die Garzeit einzustellen.

Ihr Backofen ist mit der Funktion "SMART ASSIST" ausgestattet, die Ihnen bei einer Programmierung der Dauer eine veränderbare Garzeit empfiehlt, gemäß der gewählten Garmethode. Siehe folgende Tabelle:

GAR FUNKTION (je nach Modell)	EMPFEHLUNG DER ZEIT
 HERKÖMLICH	30 Min.
 HERKÖMLICH/ GEPULSTE UNKTIONEN	30 Min.
 UMLUFT	30 Min.
 GEPULSTE HERDBODENFUNKTION	30 Min.
 ECO	30 Min.
 GRILL MITTEL	10 Min.
 GRILL STARK	7 Min.
 GEPULSTE GRILLFUNKTION	15 Min.
 WARMHALTEN	60 Min.
 PIZZA	15 Min.
 BOOST	5 Min.

Das gewünschte Ende der Garzeit wird automatisch nach einigen Sekunden abgespeichert. Der Countdown für die eingestellte Dauer läuft sofort, sobald die Gartemperatur erreicht ist.

## 4.4 ZEITLICH VERZÖGERT BEGINNENDER GARVORGANG

Wie bei programmierter Dauer vorgehen. Nach dem Einstellen der Gardauer drücken Sie auf Taste , das Garzeitende  blinkt.

Die Anzeige blinkt, stellen Sie das Garzeitende mit + oder - ein.

Das gewünschte Ende der Garzeit wird automatisch nach einigen Sekunden abgespeichert. Die Anzeige für die Garzeitbeendigung blinkt nicht mehr.

## 5 Reinigung

### REINIGUNG DER AUSSENFLÄCHE

Benutzen Sie ein weiches, mit Glasreiniger getränktes Tuch. Weder Scheuermittel noch Scheuerschwamm verwenden.

### 5.1 AUSBAU DER EINSCHUBLEISTEN

Den vorderen Teil der Einschubleisten anheben, leicht auf die gesamte Einschubleiste drücken und den vorderen Haken aus seiner Aufnahme ausrasten. Anschließend die gesamte Einschubleistenhalterung leicht zu sich hin ziehen, um die hinteren Haken aus ihrer Aufnahme auszurasten. So können beide Einschubleisten herausgenommen werden.

### 5.2 REINIGUNG DER INNEREN SCHEIBEN

Nehmen Sie zum Reinigen der inneren Scheiben die Tür ab. Entfernen Sie vor dem Herausnehmen der Scheiben das überschüssige Fett auf der inneren Scheibe mit einem weichen Tuch und Spülmittel.

#### **Warnung**

**Für das Reinigen der Glastür des Ofens dürfen keine Scheuermittel, Scheuerschwämme oder Metallschaber verwendet werden, wodurch Kratzer auf der Oberfläche oder Sprünge im Glas verursacht werden könnten.**

#### AUSBAU

Öffnen Sie die Tür vollständig und blockieren Sie sie mithilfe des Plastikkeils, das in der mit dem Gerät gelieferten Plastiktüte enthalten ist.

Entfernen Sie die erste mit Clip befestigte Scheibe: Drücken Sie mithilfe eines Werkzeugs (Schraubendreher) in die Öffnungen , um die Scheibe aus der Cliphalterung zu lösen.

Entfernen Sie die Scheibe.

Je nach Modell besteht die Tür aus zwei zusätzlichen

Scheiben mit einem schwarzen Abstandsbolzen aus Gummi an jeder Ecke. Falls nötig, entfernen Sie diese, um sie zu reinigen.

Die Scheiben nicht in Wasser tauchen. Mit klarem Wasser spülen und mit einem nicht fuselnden Tuch trocknen.

### WIEDEREINSETZEN DER TÜR

Stellen Sie die vier schwarzen Distanzstücke aus Gummi nach der Reinigung wieder mit dem Pfeil nach oben zurück und bringen Sie alle Scheiben wieder an. Rasten Sie die letzte Scheibe in die Distanzstücke aus Metall ein, befestigen Sie sie dann mit der glänzenden Seite nach außen.

Entfernen Sie den Plastikkeil.

Ihr Gerät ist nun wieder betriebsbereit.

## 5.3 ERSETZEN DER LAMPE

### Techn. Daten der Glühlampe:

15 W, 220-240 V~, 300°C, Sockel E14.



Die Glasabdeckung und die Lampe lassen sich leichter herausdrehen, wenn ein Gummihandschuh getragen wird.

 **Warnung:**  
Um die Gefahr eines Stromschlags auszuschließen, vor Austausch der Lampe sicherstellen, dass die Stromversorgung des Ofens abgeschaltet ist. Den Eingriff nur bei kaltem Ofen vornehmen.

## 6 Einstellungen

### 6.1 MENÜ

Sie können verschiedene Einstellungen Ihres Backofens verändern, dafür:

Drücken Sie die Taste  bis zur "MENÜ"-Anzeige, um zum Einstellmodus zu gelangen. Drücken Sie erneut die Taste , um die verschiedenen Einstel-

lungen durchlaufen zu lassen.

Aktivieren oder deaktivieren Sie mit den Tasten + und - die verschiedenen Einstellungen, siehe folgende Tabelle:

	Aktivieren/Deaktivieren Sie die Signaltöne der Tasten
	Aktivieren/Deaktivieren Sie den Vorführmodus

Um das "MENÜ" zu verlassen, drücken Sie erneut auf .

# 7 ? Funktionsstörungen

**Der Backofen heizt nicht.** Kontrollieren Sie, ob der Ofen tatsächlich an das Stromnetz angeschlossen ist und ob die Sicherung Ihrer Elektroinstallation intakt ist. Höhere Temperatur einstellen.

**Die Lampe des Backofens funktioniert nicht.** Tauschen Sie die Lampe bzw. die Sicherung aus. Kontrollieren Sie, ob der Ofen tatsächlich an das Stromnetz angeschlossen ist.

**Das Kühlgebläse läuft nach Abschalten des Backofens weiter.** Das ist normal, die Ventilation kann bis maximal eine Stunde nach dem Garen weiterlaufen, um die Innen- und die Außentemperatur des Ofens abzusenken. Wenn das Kühlgebläse länger als eine Stunde weiter läuft, wenden Sie sich bitte an den Kundendienst.

# 8 Umgebung

## UMWELTSCHUTZ

Das Verpackungsmaterial des Gerätes ist recyclingfähig. Führen Sie es der Wiederverwertung zu und leisten Sie einen Beitrag zum Umweltschutz, indem Sie es in den dazu vorgesehenen Containern Ihrer Gemeinde entsorgen.



In das Gerät wurden viele recyclingfähige Materialien eingebaut. Dieses Logo bedeutet, dass Altgeräte nicht zusammen mit anderen Abfällen entsorgt werden dürfen.

Die vom Hersteller organisierte Wiederverwertung erfolgt unter optimalen Bedingungen und hält die europäische Richtlinie 2002/96/EG für Abfälle aus elektrischen und elektronischen Geräten ein.

Fragen Sie in der Gemeindeverwaltung oder bei Ihrem Händler nach den nächstgelegenen Sammelpunkten für Altgeräte.

Wir danken für Ihren Beitrag zum Umweltschutz.

# 9 Kundendienst

## REPARATURARBEITEN

Eventuelle Reparaturarbeiten an dem Gerät müssen von qualifiziertem Fachpersonal des Händlers vorgenommen werden. Um bei Ihrem Anruf die Entgegennahme Ihres Anliegens zu erleichtern, halten Sie bitte die vollständigen Geräteangaben bereit (Handels-Referenznummer, Service-Referenznummer, Seriennummer). Diese Angaben finden Sie auf einem an Ihrem Gerät angebrachten Schild.

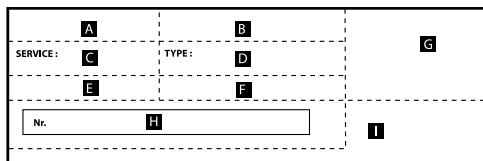
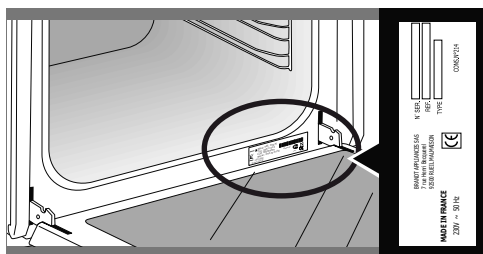

B: Handelsreferenznummer





C: Service-Referenznummer

H: Seriennummer





## ORIGINAL-ERSATZTEILE

Verlangen Sie bei Reparaturarbeiten, dass ausschließlich **zertifizierte Original-Ersatzteile verwendet werden.**



GERICHTE	 *		 *		 *		 *		 *		 *		 *		 *		Min.	
		EBENE		EBENE		EBENE		EBENE		EBENE		EBENE		EBENE		EBENE		
<b>Fleisch</b>																		
Schweinebraten (1kg)	200	2					180	2										60
Kalbsbraten (1kg)	200	2					180	2										60-70
Rinderbraten	240	2																30-40
Lamm (Keule, Schulter 2,5 kg)	220	1			220						200	2						60
Geflügel (1 kg)	200	2			220		180	2			210	3						60
Große Geflügelstücke	180	1																60-90
Hähnchenschenkel					220	3					210	3						20-30
Schweine-/Kalbskotelett					210	3												20-30
Rinderkotelett (1kg)					210	3					210	3						20-30
Schafskotelett					210	3												20-30
<b>Fisch</b>																		
Gegrillter Fisch					275	4												15-20
Fischgerichte	200	3					180	3										30-35
Gegarter Fisch	220	3					200	3										15-20
<b>Gemüse</b>																		
Aufläufe (gegarte Lebensmittel)					275	2												30
Kartoffelauflauf	200	2					180	2										45
Lasagne	200	3					180	3										45
Gefüllte Tomaten	170	3					160	2										30
<b>Gebäck</b>																		
Biskuit - Biskuitkuchen			180	2									180	2				35
Biskuitrolle	220	3											180	2				5-10
Brioche	180	1	210										180	2				35-45
Brownies	180	2					175	3										20-25
Kuchen - Sandkuchen	180	1	180	1									180	2				45-50
Clafoutis	200	2					180	3										30-35
Cremes	165	2											150	2				30-40
Kekse - Mürbegebäck	175	3																15-20
Gugelhupf			180	2									180	2				40-45
Baisers	100	2											100	3				60-70
Madeleines	220	3					200	3										5-10

\* Je nach Modell

GERICHTE	 *		 *		 *		 *		 *		 *		 *			
		EBENE		EBENE		EBENE		EBENE		EBENE		EBENE		EBENE	Min.	
<b>Gebäck</b>																
Madeleines	220	3					200	3								5-10
Windbeutel	200	3					180	3					180	3		30-40
Blätterteigteilchen	220	3					200	3								5-10
Savarin	180	3											175	3		30-35
Mürbeteig-Tarte	200	1					195	1								30-40
Feine Blätterteig-Tarte	215	1					200	1								20-25
Mürbeteig-Tarte mit Hefe	210	1					200	1								10-30
<b>Verschiedenes</b>																
Spießbraten	220	3			210	4										10-15
Schüsselpastete	200	2					190	2								80-100
Mürbeteig-Pizza	200	2														30-40
Brotteig-Pizza																15-18
Quiches																35-40
Soufflé													180	2		50
Pasteten	200	2														40-45
Brot	220						200		220							30-40
Gegrilltes Brot	180				275	4-5										2-3
Gerichte im Schmortopf (Schmorbraten)	180	2											180	2		90-180

\* Je nach Modell

**Alle Temperatur- und Gardauerangaben gelten für vorgeheizte Öfen.**

Hinweis: Alle Fleischarten müssen mindestens 1 Stunde bei Raumtemperatur liegen, bevor sie in den Backofen geschoben werden.

**ENTSPRECHUNG: ZIFFERN  °C**

°C	30	60	90	120	150	180	210	240	275
<b>Ziffern</b>	<b>1</b>	<b>2</b>	<b>3</b>	<b>4</b>	<b>5</b>	<b>6</b>	<b>7</b>	<b>8</b>	<b>Max. 9</b>

## Rezepte mit Hefe (je nach Modell)

Zutaten:

• Mehl 2 kg • Wasser 1240 ml • Salz 40 g • 4 Päckchen getrocknete Backhefe

Den Teig mit dem Mixer vermischen und im Ofen aufgehen lassen.

**Durchführung:** Für Rezepte mit Hefeteig. Füllen Sie den Teig in eine hitzebeständige Schüssel, entfernen Sie die Einschubleistenhalterungen und stellen Sie die Schüssel auf dem Backofenboden ab.

**Heizen Sie den Backofen mit der Umluftfunktion bei 40-50 °C 5 Minuten lang vor. Schalten Sie den Backofen aus und lassen Sie den Teig 25-30 Minuten in der Restwärme aufgehen.**

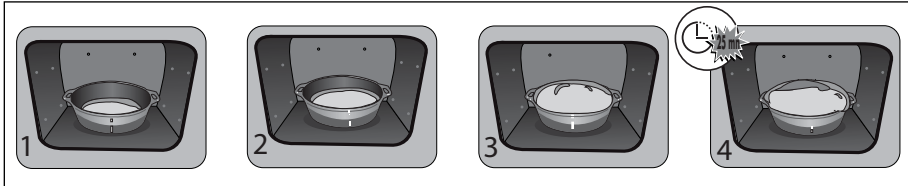

## VERFAHREN ZUR MESSUNG DER GEBRAUCHSEIGENSCHAFTEN LAUT NORM IEC 60350

NAHRUNGSMITTEL	* GAR-EIN- TELLUNG	POSITION	ZUBEHÖR	t °C	DAUER Min.	VORHEIZEN
Spritzgebäck (8.4.1)		5	Backblech 45 mm	150	30-40	ja
Spritzgebäck (8.4.1)		5	Backblech 45 mm	150	25-35	ja
Spritzgebäck (8.4.1)		2 + 5	Backblech 45 mm + Rost	150	25-45	ja
Spritzgebäck (8.4.1)		3	Backblech 45 mm	175	25-35	ja
Spritzgebäck (8.4.1)		2 + 5	Backblech 45 mm + Rost	160	30-40	ja
Small cakes (8.4.2)		5	Backblech 45 mm	170	25-35	ja
Small cakes (8.4.2)		5	Backblech 45 mm	170	25-35	ja
Small cakes (8.4.2)		2 + 5	Backblech 45 mm + Rost	170	20-40	ja
Small cakes (8.4.2)		3	Backblech 45 mm	170	25-35	ja
Small cakes (8.4.2)		2 + 5	Backblech 45 mm + Rost	170	25-35	ja
Wasserbiskuitorte (8.5.1)		4	Rost	150	30-40	ja
Wasserbiskuitorte (8.5.1)		4	Rost	150	30-40	ja
Wasserbiskuitorte (8.5.1)		2 + 5	Backblech 45 mm + Rost	150	30-40	ja
Wasserbiskuitorte (8.5.1)		3	Rost	150	30-40	ja
Wasserbiskuitorte (8.5.1)		2 + 5	Backblech 45 mm + Rost	150	30-40	ja
Gedeckter Apfelkuchen (8.5.2)		1	Rost	170	90-120	ja
Gedeckter Apfelkuchen (8.5.2)		1	Rost	170	90-120	ja
Gedeckter Apfelkuchen (8.5.2)		3	Rost	180	90-120	ja
Toast bräunen (9.2.2)		5	Rost	275	3-6	ja

\* Modellabhängig

**HINWEISS:** Beim Garen auf 2 Ebenen können die Gerichte nach unterschiedlichen Zeiten herausgenommen werden.





Kære kunde,

Du har lige anskaffet et BRANDT produkt, og vi takker for tilliden du viser os.

Vi har udviklet og fremstillet dette produkt med tanke på dig, din livsstil og dine behov, for at det på bedste måde skal imødekomme dine forventninger. Dette produkt har vi lagt vores knowhow, vores innovationsindsats og al den lidenskab, der har drevet os i mere end 60 år.

I vores utrættelige bestræbelser på altid at tilfredsstille vores kunders behov endnu bedre står vores kundeservice naturligvis til rådighed for at besvare alle dine spørgsmål og lytte til dine forslag.

Du kan også gå ind på vores website på [www.brandt.com](http://www.brandt.com), hvor du finder alle vores seneste innovationer, samt nyttige supplerende oplysninger.

**BRANDT** er glad for at følge dig i din hverdag og vi håber, at du vil få det bedste udbytte af dit køb.



**Vigtigt: Inden apparatet tages i brug, bør du læse denne installations- og brugsvejledning grundigt, så du hurtigt kan sætte dig ind i dets funktioner**

## VIGTIGE SIKKERHEDSREGLER

### VIGTIGE SIKKERHEDSREGLER, SOM SKAL LÆSES NØJE OG GEMMES TIL FREMTIDIG BRUG.

Denne brugervejledning kan downloades fra mærkets internetsted.

 Når du modtager apparatet, skal du straks pakke det ud eller straks få det pakket ud. Kontrollér den generelle fremtoning. Få eventuelle forbehold noteret på fragsedlen, og behold en kopi af den.

#### Vigtigt:

Dette apparat kan bruges af børn på 8 år og derover og af personer med nedsatte fysiske, sensorielle eller mentale evner eller som er blottet for erfaring eller kendskab, hvis de er under opsyn eller har fået forudgående instruktioner om en sikker anvendelse af apparatet og har forstået de risici, de udsætter sig for.

— Børn må ikke lege med apparatet. Rengøring og vedligeholdelse må ikke udføres af børn uden opsyn.

— Børn bør overvåges for at sikre, at de ikke leger med apparatet.

#### ADVARSEL:

— Selve ovnen og de tilgængelige dele bliver meget varme under brug. Pas på ikke at røre ved varmeelementerne inde i ovnen. Børn på under 8 år skal holdes på afstand, medmindre de er under konstant opsyn.

— Dette apparat er beregnet til madlavning med lukket ovndør.

— Før du foretager en pyrolyse rengøring af ovnen, skal du tage

alle tilbehørsdele ud og fjerne de værste overstænkninger.

— I rengøringsfunktion kan ovns overflader blive mere varme end under normal brug. Det anbefales at holde børn på afstand.

Det anbefales at holde børn på afstand.

— Der må ikke anvendes damprenseapparat.

— Der må aldrig anvendes slibemidler, slibesvampe eller metalsvampe til rengøring af ovnlåger af glas, da dette kan ridse overfladen og måske føre til, at ruden sprænger.



#### PAS PÅ :

Sørg for, at apparatet er frakoblet strømforsyningen, før lampen udskiftes for at undgå elektrisk stød. Vent, indtil apparatet er afkølet. Brug en gummihandske til at skrue lampeglasset af og tage pæren ud for at lette afmonteringen.



Efter installation skal stikkontakten være tilgængelig. Det skal være muligt at koble apparatet fra strømforsyningsnettet, enten ved hjælp af en stikforbindelse eller ved at indbygge en afbryder i de permanente rørdninger i overensstemmelse med installationsreglerne.

## VIGTIGE SIKKERHEDSREGLER

— Hvis forsyningskablet beskadiges, skal det udskiftes af fabrikanten eller dennes kundeservice eller en lignende kvalificerede person for at undgå enhver fare.

— Dette apparat kan installeres på et køkkenbord eller indbygges i et møbel som angivet på installationsskemaet.

— Sæt ovnen ind i et møbel, således at der er en minimal afstand på 10mm til møblet ved siden af. Det møbel, som ovnen bygges ind i, skal være lavet af et varmebestandigt materiale (eller være beklædt med et varmebestandigt materiale). For at opnå større stabilitet skal ovnen fastgøres i møblet med de 2 skruer gennem de huller, der er forudset til det.

— Apparatet må ikke installeres bag en låge, da det kan give overophedning.

— Dette apparat er udelukkende beregnet til anvendelser i private hjem og lignende steder såsom:

Køkkenhjørner forbeholdt personalet i butikker, på kontorer og i andre professionelle omgivelser.

På gårde. Anvendelse af kunder på hoteller, moteller og andre beboelsemæssige omgivelser; omgivelser af typen bed & breakfast.

— Ovnen skal være standset, før ovnkammeret gøres rent.

Brug aldrig ovnen som opbevaringssted for mad eller ting, når den ikke er i brug.

Der må ikke foretages ændringer i dette apparats egenskaber, det kan udgøre en fare for dig.

# 1 Præsentation af ovnen

## 1.1 PRÆSENTATION AF OVNE

- A** Betjeningspanel
- B** Lampe
- C** Låge
- D** Håndgreb

Denne ovn har 6 ribbepositioner til tilbehørsdele: ribbe 1 til 6.

## 1.2 VISNING PÅ DISPLAY



- Tilberedningstid
- Slutning på tilberedning
- Spærring af tastatur
- Minutur
- Temperaturindikator
- Indikator for forvarmning
- Låsning af låge

## 1.3 TASTER

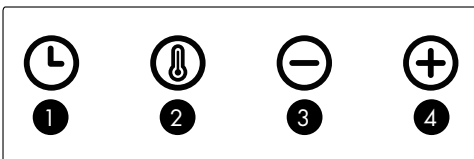

- 1** Indstilling af klokken og varighed
- 2** Indstilling af temperatur
- 3** - tasten
- 4** + tasten

## 1.4 TILBEHØR (ifølge modellen)

### A • Sikker rist, der ikke kan vippe

Risten kan anvendes til at stille fade og forme ind i ovnen med retter, som skal steges eller gratineres. Den kan også anvendes til at grillstege kød (lægges direkte på risten).

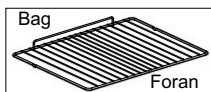

Risten, der er sikret mod vipning, skubbes ind i ovnen.

### B • Universal bradepande 45 mm

Indsættes i ribberne under risten med håndgrebet mod ovnlågen. Den kan opsamle saft og kraft fra det grillstegte kød. Den kan også fyldes halvt med vand til tilberedning i vandbad.

### C • Bageplade 20 mm

Indsættes i ribberne med håndgrebet mod ovnlågen. Meget god til bagning af cookies, småkager, tørkager, små kager i form. Dens hældende form gør det let at flytte dine tilberedninger til et fad. Kan også indsættes i ribberne under risten for at opsamle kraft, saft og fedt fra grillstegt kød.

### Godt råd

**For at forhindre at der opstår mados under tilberedning af fedt kød anbefaler vi, at der tilsættes en lille smule vand eller olie i bunden af bradepanden.**

# 2 Installation

## 2.1 VALG MELLEMLACERING OG INDBYGNING

Diagrammerne viser, hvilke mål et møbel skal have, for at ovnen kan sættes ind i det.

Dette apparat kan installeres enten under en plade (**A**) eller i kolonne (**B**). Hvis møblet er åbent, skal åbningen være på højst 70 mm bagpå.

Fastgør ovnen i møblet. For at gøre dette tages gummiholderne ud, og der forbores et hul med en diameter på 2 mm i møblets væg for at undgå, at træet sprækker. Fastgør ovnen ved hjælp af de to skruer. Sæt gummiholderne på plads igen.

### Godt råd

**For at være sikker på, at installationen er lovlig, bør du kontakte en el-installatør.**

### Vigtig

**Før du tager ovnen i brug første gang, skal du tænde for den og lade den varme op til 200 °C i ca. 1 time.**

**Sørg for, at lokalet bliver luftet godt ud.**

## ELEKTRISK TILSLUTNING

Ovnen skal tilsluttes med et standard strømføringskabel med tre ledere på 1,5 mm<sup>2</sup> (1 fase + 1 neutral + jord), som skal være sluttet til elnet med 220~240 volt ved brug af et standard strømstik CEI 60083 eller en omnipolær afbryderanordning iht. gældende bestemmelser for installation.

Beskyttelsesledningen (grøn-gul) forbindes til apparatets klemskrue  og installationen skal have jordforbindelse. Installationens sikring skal være på 16 A.

Vi kan ikke drages til ansvar for ulykker eller uheld på grund af en manglende, beskadiget eller ukorrekt jordforbindelse eller i tilfælde af ikke korrekt tilslutning.

### OBS:

**Hvis den elektriske installation i hjemmet skal ændres eller tilpasses for at tilslutte apparatet, skal dette udføres af en kvalificeret elektriker. Hvis der konstateres en beskadigelse, skal ovnen afbrydes, eller ovenns sikring fjernes.**

## 3



### Indstilling af klokken

### 3.1 INDSTILLING AF KLOKKEN

Når ovnen tændes, blinker displayet på 12:00.

Klokken indstilles med tasten+ eller -.

Godkend med tasten .

Ved strømafbrydelse blinker visningen af klokken med tidspunktet for strømafbrydelsen 12:00.

### 3.2 ÆNDRING AF KLOKKEN

Funktionsvælgeren skal stå på position 0.

Tryk på tasten  symbolet for minutur vises .

tryk igen på , juster indstillingen af klokken med tasten + eller -.

Godkend med tasten .

### 3.3 MINUTUR

**Denne funktion kan kun anvendes, når ovnen er slukket.**

Tryk på tasten .

Symbolet for minutur blinker.

Indstil minuturet med tasten+ eller -.

Tryk på tasten  for at godkende, og nedtællingen begynder.

Når tiden er forløbet, udsendes et lydsignal. Tryk på en hvilken som helst tast for at stoppe lydsignalet. Klokken vises på displayet.

NB: Du kan når som helst ændre eller annullere indstillingen af minuturet. For at annullere og vende tilbage til menuen for minutur og indstille til 00:00. Uden godkendelse udføres registreringen automatisk efter få sekunder

## 3.4 SPÆRRING AF TASTATUR

Tryk samtidigt på tasterne + og -, indtil symbolet



vises på skærmen. For at oplåse trykkes samtidigt på tasten + og -, indtil symbolet  forsvinder fra skærmen.

## 4



### Tilberedning

### TILBEREDNINGSFUNKTIONER

(ifølge modellen)



#### ROTTERENDE VARMLUFT\*

Min. temperatur 35°C, maks. temperatur 235°C

Anbefales til hvidt kød, fisk og grønsager for at bevare en rund og fyldig smag. Til flere tilberedninger samtidigt på op til 3 niveauer.



#### TRADITIONEL VARMLUFT

Min. temperatur 35°C, maks. temperatur 275°C

Anbefales til kød, fisk, grøntsager, som helst skal lægges på et lerfad.



#### VARMLUFTS GRILL

Min. temperatur 180°C, maks. temperatur 230°C

Fjerkræ og stege bliver saftige og sprøde på alle sider.

Stil brædepannen ind på nederste ribbe.

Anbefales til fjerkræ eller steg, til at brune og gennemstege lammekøller, oksekoteletter. Til at bevare fiskebøffer bløde indeni.



#### KUN VARMLUFT

Min. temperatur 75°C, maks. temperatur 250°C

Anbefales til fugtige retter (quiche, saftige frugttærter m.m.).Dejen bliver mere sprød på undersiden. Anbefales til tilberedninger der hæver (kage, brioche, kouglof m.m) og til souffléer, som ikke bliver forhindret i at hæve af en skorpe oven på.



#### TRADITIONEL OVN

Min. temperatur 35°C, maks. temperatur 275°C

Anbefales til en langsom og udsøgt tilberedning: Vildt steg m.m. Til at brune en oksesteg. Til langtidstegning i stegesko eller cocotte af gryderetter, som er startet på komfur (coq au vin, ragout).



Min. temperatur 35°C, maks. temperatur 250°C  
Denne position muliggør en energibesparelse og bevarer samtidigt bagingens kvalitet.  
Al tilberedning sker uden forvarmning.



Min. temperatur 180°C, maks. temperatur 275°C  
Anbefales til at grille toasts, gratinere en ret, brune en crème brûlée.



Min. temperatur 35°C, maks. temperatur 100°C  
Anbefales til at hæve dej til brød, brioche, kouglof.  
Form sat i bunden, må ikke overstige 40°C (tallerkenvarmer, optøning).



Min. temperatur 35°C, maks. temperatur 275°C  
For at garantere for et god resultat for dine pizzaer, skal de sættes i 3. ribbe i en varm ovn.



Min. temperatur 35°C, maks. temperatur 275°C  
Giver hurtig temperaturstigning i ovnen.

*\*Tilberedningsmetode udført ifølge forskrifterne i normen EN 60350-1: 2016 for at påvise overensstemmelse med kravene for energimærkning i EU forordningen UE/65/2014.*

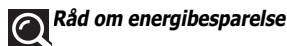

**Hold ovnlågen lukket under tilberedningen.**

## 4.1 ØJEBLIKkelig TILBEREDNING

Betjeningspanelet må kun vise klokkeslættet. Og det må ikke blinke.  
Stil funktionsvælgeren på den ønskede position.  
Temperaturstigningen starter straks. Ovnens anbefaler en temperatur, der kan ændres.  
Ovnens varmer, og indikatoren for temperatur blinker. Ovnens udsender en række bip, når ovnen har nået den programmerede temperatur.

## 4.2 ÆNDRING AF TEMPERATUREN

Tryk på .  
Juster temperaturen med + eller -.  
Godkend ved at trykke på .

## 4.3 PROGRAMMERING AF VARIGHED

Udfør en øjeblikkelig tilberedning, og tryk derefter på , tilberedningstiden blinker, og indstillingen er nu mulig. Tryk på + eller - for at indstille tilberedningstiden.  
Ovnens er udstyret med funktionen "SMART ASSIST", som ved en programmering af varighed vil foreslå en tilberedningstid, der kan ændres, i forhold til den valgte tilberedningsmåde.  
Se tabellen herunder:

TILBEREDNINGS FUNKTIONER (ifølge modellen)	ANBEFALINGER AF VARIGHED
TRADITIONEL OVN	30 min.
TRADITIONEL VARMLUFT	30 min.
ROTERENDE VARMLUFT	30 min.
KUN VARMLUFT	30 min.
ØKO	30 min.
MIDDEL GRILL	10 min.
STÆRK GRILL	7 min.
VARMLUFTS GRILL	15 min.
HOLDE VARM	60 min
PIZZA	15 min.
BOOST	5 min.

Indlæsningen af tilberedningens varighed sker automatisk efter nogle sekunder. Nedtælling af varigheden starter straks, når tilberedningstemperaturen er opnået.

## 4.4 TILBEREDNING MED UDSKUDT START

Følg samme fremgangsmåde som for programmeret varighed. Efter indstilling af tilberedningstiden trykkes på tasten . Visningen blinker, indstil klokkeslæt for afslutning af tilberedning med + eller -.  
Indlæsningen af slutning på bagning sker automatisk efter nogle sekunder. Visningen af slutning på tilberedning blinker ikke mere.

## 5



## Tilberedningsguide

**RENGØRING AF OVNE UDVENDIGT**

Brug en blød klud, fugtet med produkt til ruder. Brug aldrig skurecreme eller skuresvampe.

**RENGØRING AF OVNE INDVENDIGT**

Rengør en stadig håndvarm ovn med en klud fugtet med varmt sæbevand, og aftør med en fnugfri klud.

**5.1 AFMONTERING AF RIBBER OG UDSKIFTNING AF KATALYTISKE VÆGGE****Sidevægge med ribber :**

Løft forreste del af ribberne opad, skub hele ribben, så forreste krog går ud af hullet. Træk derefter ribberne udad mod dig selv, så de bageste kroge kommer ud af hullerne. Fjern således de 2 ribber og **de katalytiske vægge. Udsift med de nye elementer (vægge) ved at gå frem i omvendt rækkefølge.**

**5.2 RENGØRING AF INDVENDIG OVERFLADE**

Lågen afmonteres for at rengøre glasruden indvendigt. Før afmonteringen fjernes fedt på indersiden af glasset med en blød klud fugtet i opvaskemiddel.

**⚠ Advarsel**

**Der må aldrig anvendes skurepulver, svampe der ridser eller svampe af metal til rengøring af ovnlåger af glas, da dette kan ridse overfladen og måske føre til, at glasset sprænger.**

**AFMONTERING**

Åbn lågen helt, og bloker den ved brug af plastkilen i plastposen, der følger med apparatet.

Tag den fastklipsede rude ud:

Tryk ved brug af et værktøj (skruetrækker) ned på placeringerne **A** for at afklipse glasset.

Tag glasset ud.

Glasset må ikke lægges i vand. Skyl med rent vand, og tør efter med et rent viskestykke.

**GENMONTERING AF OVNLÅGEN**

Efter rengøringen sættes ruden på plads igen og den fastgøres i metalholderne, og klipses derefter fast med den skinnende side udad.

Tag plastkilen ud.

Nu er apparatet klar til brug igen.

**5.3 UDSKIFTNING AF PÆREN****Advarsel:**

Sørg for, at apparatet er slukket og ledningen taget ud før udskiftning af ovnlampe for at undgå elektrisk stød. Vent, indtil apparatet er nedkølet.

**Pærens egenskaber:**

15 W, 220-240 V~, 300°C, sokkel E14.

Brug en gummihandske til at skrue lampeglasset af og tage pæren ud for at lette afmonteringen.

## 6

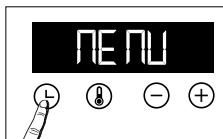

## Rengøring

**6.1 MENU**

Du kan lave flere forskellige indstillinger på ovnen. For at gøre dette:

Tryk på tasten , indtil "MENU" vises, for at komme til tilstand for

indstilling. Tryk igen på tasten  for at gennemse de forskellige indstillinger.

Aktiver eller deaktiver med tasterne + et - de forskellige parametre, se tabellen herunder:

	Aktiver/deaktiver tasternes bip
	Aktiver/deaktiver demo-funktion

For at gå ud af "MENU" trykkes igen på .

7

?

## Indstillinger

**Ovnen varmer ikke op.** Kontrollér, om ovnen får tilført strøm, eller om der er sprunget en sikring i din eltavle. Øg den valgte temperatur.

**Lampen i ovnen fungerer ikke.** Udskift pæren eller sikringen. Kontrollér, om ovnen er tilsluttet elnettet.

**Køleventilatoren fortsætter med at køre efter slukning af ovnen.** Det er helt normalt, at ventilationen kan køre helt op til maks. én time efter tilberedning i ovnen. Det sker for at sænke temperaturen inde i ovnen. Hvis det fortsætter ud over en time kontaktes kundeservice.

**Man kan ikke rense ovnen ved brug af pyrolyse.** Kontrollér, at ovndøren er lukket korrekt. Hvis det drejer sig om en fejl ved lukning af døren eller ved temperaturføleren, kontaktes kundeservice.

8



## Miljø

## PAS PÅ MILJØET

Emballagematerialerne til dette apparat kan genbruges. Du kan sørge for, at det bliver genbrugt og dermed være med til at beskytte miljøet ved at bortskaffe dem på genbrugspladsen.

Apparatet indeholder ligeledes flere genanvendelige materialer. Dette angives med den illustrerede tegning for at vise, at brugte apparater ikke må blandes sammen med almindeligt husholdningsaffald.



— Genvindingen af apparater, som producenten organiserer, sker under de mest optimale betingelser i overensstemmelse med Europa-Parlamentets og Rådets direktiv 2002/96/EF om affald af elektrisk og elektronisk udstyr.

Kontakt rådhuset/ kommunen eller forhandleren for at få at vide, hvor brugte apparater kan afleveres i nærheden af din bopæl.

Vi takker for dit samarbejde med hensyn til at beskytte miljøet.

9



## Indgreb

## INDGREB

Eventuelle indgreb på apparatet skal foretages af en kvalificeret tekniker, som er autoriseret af mærket. Når du ringer til os, skal du, for at vi bedre kan hjælpe dig, have alle oplysningerne om dit apparat klar (salgsartikel nr., servicereference, serienummer). Disse oplysninger står på typeskiltet.

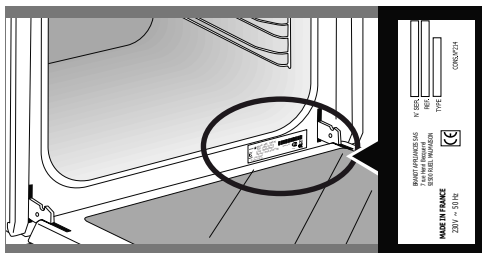

SERVICE: <b>A</b>		TYPE: <b>B</b>		<b>G</b>
<b>C</b>		<b>D</b>		
<b>E</b>		<b>F</b>		
Nr. <b>H</b>				<b>I</b>

B: Forhandlingsreference

C: Servicereference

H: Serienummer















## ORIGINALDELE:

I forbindelse med reparationer skal du anmode om, at der kun anvendes *originaldele*.



RETTER	 *		 *		 *		 *		 *		 *		 *			
		TRIN		TRIN		TRIN		TRIN		TRIN		TRIN		TRIN	min	
<b>Kød</b>																
Svinesteg (1 kg)	200	2					180	2								60
Kalvesteg (1 kg)	200	2					180	2								60-70
Oksesteg	240	2														30-40
Lam (kølle, bov 2,5 kg)	220	1			220						200	2				60
Fjerkræ (1 kg)	200	2			220		180	2			210	3				60
Fjerkræ, store dele	180	1														60-90
Kyllingelår					220	3					210	3				20-30
Svine/kalvekoteletter					210	3										20-30
Oksekoteletter (1 kg)					210	3					210	3				20-30
Fårekoteletter					210	3										20-30
<b>Fisk</b>																
Grillet fisk					275	4										15-20
Kogt fisk (havrude/brasen)	200	3					180	3								30-35
Indpakket fisk	220	3					200	3								15-20
<b>Grøntsager</b>																
Gratiner (tilberedte madvarer)					275	2										30
Kartoffelgratin	200	2					180	2								45
Lasagner	200	3					180	3								45
Farserede tomater	170	3					160	2								30
<b>Kager</b>																
Sukkerbrødsrage - Sandkage			180	2									180	2		35
Rullede småkager	220	3											180	2		5-10
Brioche	180	1	210										180	2		35-45
Brownies	180	2					175	3								20-25
Cake - Pund-til-pund	180	1	180	1									180	2		45-50
Clafoutis	200	2					180	3								30-35
Cremer	165	2											150	2		30-40
Cookies - tørkager	175	3														15-20
Kugelhøp			180	2									180	2		40-45
Marengs	100	2											100	3		60-70
Madeleinekager	220	3					200	3								5-10

\* afhængig af model

RETTER	 *		 *		 *		 *		 *		 *		 *			
		TRIN		TRIN		TRIN		TRIN		TRIN		TRIN		TRIN	min	
<b>Kager</b>																
Madeleinekager	220	3					200	3								5-10
Vandbakkelser	200	3					180	3					180	3		30-40
Petit fours af butterdej	220	3					200	3								5-10
Savarinkage	180	3											175	3		30-35
Mørdej	200	1					195	1								30-40
Butterdej til tærte	215	1					200	1								20-25
Gærdej til tærte	210	1					200	1								10-30
<b>Diverse</b>																
Spyd	220	3			210	4										10-15
Postej	200	2					190	2								80-100
Pizzamørdej	200	2														30-40
Pizzagærdej																15-18
Quiche																35-40
Soufflé													180	2		50
Pie	200	2														40-45
Brød	220						200		220							30-40
Ristet brød	180				275	4-5										2-3
Lukket trykkoger (stuvning)	180	2											180	2		90-180

\* afhængig af model

**Alle T°C og tilberedningstider er opgivet for forvarmede ovne.**

Før kødet stilles i ovnen skal det have stået i mindst en time ved stuetemperatur.

ÆKVIVALENS: TAL  °C									
°C	30	60	90	120	150	180	210	240	275
Tal	1	2	3	4	5	6	7	8	9 maxi

## Opskrift med gær (ifølge modellen)

Ingredienser:

• Mel 2 kg • Vand 1240 ml • Salt 40 g • 4 pakker tørret gær



















Rør dejen med mikser og dejkroge, og lad dejen hæve i ovnen .

**Fremgangsmåde:** For dejopskrifter med gær. Hæld dejen i et ildfast fad, tag holderne ud af ribberne, og sæt fadet i bunden.

**Varm ovnen op med varmluftfunktionen til 40-50 °C i 5 minutter. Stands ovnen, og lad dejen hæve i 25-30 minutter i kraft af den overskydende varme.**



## TEST AF FUNKTIONENS EGNETHED IHT. STANDARDEN IEC 60350

FØDEVARE	Tilberedningsfunktioner*	TRIN	TILBEHØR	°C	TID min.	FORVARMNING
Småkager (8.4.1)		5	dyb plade	150	30-40	Ja
Småkager (8.4.1)		5	dyb plade	150	25-35	Ja
Småkager (8.4.1)		2 + 5	dyb plade + rist	150	25-45	Ja
Småkager (8.4.1)		3	dyb plade	175	25-35	Ja
Småkager (8.4.1)		2 + 5	dyb plade+ rist	160	30-40	Ja
Små cakes (8.4.2)		5	dyb plade	170	25-35	Ja
Små cakes (8.4.2)		5	dyb plade	170	25-35	Ja
Små cakes (8.4.2)		2 + 5	dyb plade + rist	170	20-40	Ja
Små cakes (8.4.2)		3	dyb plade	170	25-35	Ja
Små cakes (8.4.2)		2 + 5	dyb plade + rist	170	25-35	Ja
Saftig kage uden fedtstof (8.5.1)		4	rist	150	30-40	Ja
Saftig kage uden fedtstof (8.5.1)		4	rist	150	30-40	Ja
Saftig kage uden fedtstof (8.5.1)		2 + 5	dyb plade + rist	150	30-40	Ja
Saftig kage uden fedtstof (8.5.1)		3	rist	150	30-40	Ja
Saftig kage uden fedtstof (8.5.1)		2 + 5	dyb plade + rist	150	30-40	Ja
Æbletærte (8.5.2)		1	rist	170	90-120	Ja
Æbletærte (8.5.2)		1	rist	170	90-120	Ja
Æbletærte (8.5.2)		3	rist	180	90-120	Ja
Gratineret overflade (9.2.2)		5	rist	275	3-6	Ja

\* afhængig af model

**BEMÆRKNING:** For tilberedning i 2 niveauer kan retterne tages ud efter forskellig tilberedningstid





Caro(a) cliente,

Acaba de adquirir um produto **BRANDT** e agradecemos a confiança que depositou em nós.

Desenhámos e fabricámos este produto pensando em si, no seu modo de vida e nas suas necessidades, para poder responder da melhor forma possível às suas expectativas. Usámos o nosso conhecimento especializado, o nosso espírito inovador e toda a paixão que nos motiva desde há mais de 60 anos.

Com a preocupação constante de melhor satisfazer as suas exigências, o nosso serviço ao consumidor está à sua disposição para responder a todas as suas dúvidas ou sugestões.

Visite também o nosso site [www.brandt.com](http://www.brandt.com) onde encontrará as mais recentes inovações, bem como informação útil e complementar.

**A BRANDT** tem o prazer de acompanhá-lo(a) na sua vida quotidiana e espera que desfrute da sua compra da melhor forma possível.



**Importante: Antes de ligar o seu aparelho, leia com atenção este guia de instalação e utilização, para se familiarizar mais rapidamente com o seu funcionamento.**

## INSTRUÇÕES DE SEGURANÇA

### INSTRUÇÕES DE SEGURANÇA IMPORTANTES LER COM ATENÇÃO E CONSERVAR PARA FUTURA UTILIZAÇÃO.

Este manual está disponível para download no sítio Internet da marca.

Quando receber o aparelho, desembale-o ou peça a alguém para o desembalar imediatamente. Verifique o seu aspeto geral. Faça todas as eventuais indicações por escrito na nota de entrega e guarde um exemplar da mesma.



**Importante:**

Este aparelho pode ser utilizado por crianças com 8 anos ou mais, e por pessoas com capacidades físicas, sensoriais ou mentais reduzidas, ou desprovidas de experiência e conhecimentos, se beneficiarem de uma supervisão ou de instruções prévias acerca da utilização do aparelho de maneira segura e tiverem entendido os riscos corridos.

— As crianças não devem brincar com o aparelho. As operações de limpeza e de manutenção não devem ser realizadas por crianças sem supervisão.

— Convém supervisionar as crianças, para se certificar de que estas não brincam com o aparelho.

**CUIDADO:**

— O aparelho e as suas peças acessíveis ficam quentes durante a utilização. Não toque nos elementos de aquecimento que se encontram no interior do forno.

Crianças de menos de 8 anos devem ser mantidas afastadas, a menos que sejam constantemente supervisionadas.

— Este aparelho foi criado para fazer cozeduras com a porta fechada.

— Antes de proceder à limpeza por pirólise do forno, retire todos os acessórios e remova os derrames maiores.

— Na função de limpeza, as superfícies podem ficar mais quentes que durante a utilização normal.

Recomendamos que mantenha as crianças afastadas.

— Não utilize aparelhos de limpeza a vapor.

— Não utilize produtos de limpeza abrasivos ou raspadores metálicos duros para limpar a porta em vidro do forno, pois isso pode riscar a superfície e dar origem à ruptura do vidro.



**ADVERTÊNCIA :**

Certifique-se de que o aparelho está desligado da alimentação antes de substituir a lâmpada, para evitar qualquer risco de choques eléctricos. Intervenha quando o aparelho estiver frio. Para desapertar a tampa e a lâmpada,

## INSTRUÇÕES DE SEGURANÇA

utilize uma luva de borracha para facilitar a desmontagem.

 A ficha da tomada de corrente deve estar acessível após a instalação. Deve ser possível se desconectar da rede ou utilizar uma folha de fazer atual, ou pela incorporação de um interruptor nas canalizações fixas, de acordo com as regras de instalação.

— Se o cabo da alimentação ficar danificado, deverá ser substituído pelo fabricante, o serviço pós-venda, ou uma pessoa igualmente habilitada, de modo a evitar qualquer perigo.

— Este aparelho pode ser instalado numa bancada ou em coluna, conforme indicado no esquema de instalação.

— Centre o forno no móvel, de modo a garantir uma distância mínima de 10 mm com o móvel ao lado. O material do móvel de encastramento deve resistir ao calor (ou estar revestido com um material resistente ao calor). Para mais estabilidade, fixe o forno no móvel com 2 parafusos, através dos orifícios previstos para o efeito.

— O aparelho não deve ser instalado atrás de uma porta decorativa, para evitar o seu superaquecimento.

— Este aparelho destina-se a ser

utilizado em aplicações domésticas e análogas, tais como: áreas de cozinha reservadas ao pessoal de lojas, escritórios e outros ambientes profissionais; quintas; utilização por clientes de hotéis, motéis e outros ambientes de carácter residencial; em ambientes do tipo quarto de hotel.

— Para qualquer intervenção de limpeza na cavidade do forno, este deverá estar desligado.

Não deve modificar as características do aparelho, pois isto representa um perigo para si.

Não utilize o seu forno para guardar comida ou quaisquer outros elementos após a utilização.

# 1 Apresentação do forno

## 1.1 APRESENTAÇÃO DO FORNO

- A** Módulo de comandos
- B** Lâmpada
- C** Porta
- D** Pega

Este forno tem 6 posições de encaixes para os acessórios: encaixes de 1 a 6.

## 1.2 INDICADOR



- Duração da cozedura
- Fim da cozedura
- Bloqueio do teclado
- Temporizador
- Indicador de temperatura
- Indicador de preaquecimento
- Bloqueio da porta

## 1.3 BOTÕES

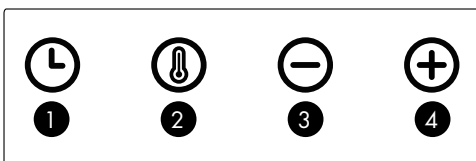

- 1** Ajuste da hora e duração
- 2** Ajuste da temperatura
- 3** Botão -
- 4** Botão +

## 1.4 ACESSÓRIOS (consoante o modelo)

### A • Grelha de segurança anti-inclinação

A grelha pode ser utilizada para colocar os pratos e formas com alimentos a cozer ou gratinar. Será utilizada para fazer grelhados (colocando-os diretamente sobre a grelha).

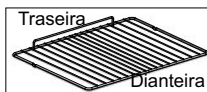

Introduzir a grelha, a pega anti-inclinação na direção do fundo do forno.

### B • Prato multiusos com pingadeira de 45 mm

Inserido nos níveis abaixo da grelha, pega na direção da porta do forno. Recolhe o sumo e gorduras dos grelhados. Pode ser utilizada meia de água para cozeduras em banho-maria.

### C • Prato de pastelaria de 20 mm

Inserido nos encaixes, pega na direção da porta do forno. Ideal para a cozedura de biscoitos, bolachas areadas, cupcakes. O plano inclinado permite colocar facilmente as preparações num prato. Também pode ser inserido nos encaixes abaixo da grelha para recolher os sumos e gorduras de grelhados.



### Conselho

**Para evitar a libertação de fumo durante a cozedura de carnes gordas, recomendamos juntar um pouco de água ou óleo no fundo da pingadeira.**

# 2



## Instalação

### 2.1 ESCOLHA DE POSICIONAMENTO E ENCASTRAMENTO

Os esquemas acima determinam as cotas de um móvel que permitirá receber um forno.

Este aparelho pode ser instalado em bancada (A) ou em coluna (B). Se o móvel for aberto, a sua abertura deve ser de 70 mm no máximo, na parte traseira. Fixe o forno com os 2 parafusos. Para este efeito, retire os batentes em borracha e faça um orifício de Ø 2 mm na parede do móvel, para evitar a ruptura da madeira. Fixe o forno com os 2 parafusos. Volte a colocar os batentes em borracha.



### Conselho

**De modo a certificar-se de que a sua instalação está conforme, não hesite em contactar um especialista em electrodomésticos.**



### Atenção

**Antes de utilizar o seu forno pela primeira vez, aqueça-o vazio a 200°C durante cerca de 1 hora. Certifique-se de que a divisão está suficientemente ventilada.**

## LIGAÇÃO ELÉTRICA

O forno deve ser ligado com um cabo de alimentação (normalizado) de 3 condutores de 1,5mm<sup>2</sup> (1ph + 1 N + terra) devendo estes ser ligados à rede monofásica de 220-240V~ através de uma tomada de corrente normalizada CEI 60083 ou de um dispositivo de corte omnipolar em conformidade com as regras de instalação.

O fio de proteção (verde-amarelo) está ligado ao terminal ⚡ do aparelho e deve ser feita uma ligação à terra. O fusível da instalação deve ser de 16 amperes.

Não nos responsabilizaremos em caso de acidente ou incidente resultante de uma ligação à terra inexistente, defeituosa ou incorreta nem em caso de uma desconexão não conforme.

### ⚠ Atenção:

Se a instalação elétrica da sua casa precisar de ser alterada para poder ligar o seu aparelho à rede, deve ligar a um electricista qualificado. Se o forno apresentar qualquer anomalia, desligue o aparelho ou retire o fusível correspondente à linha de ligação do mesmo.

3



Acertar a hora

### 3.1 ACERTAR A HORA

Quando se liga, o visor pisca e mostra 12:00. Ajustar a hora com os botões + ou -.

Valide com o botão ⏻

No caso de corte de energia, a hora começa a piscar a 12:00.

### 3.2 MUDANÇA DA HORA

O seletor de função deve obrigatoriamente estar na posição zero.

Pressione o botão ⏻ e aparece o símbolo do temporizador; ⬆ pressione novamente ⏻, acerte a hora com os botões + ou -.

Valide com o botão ⏻.

### 3.3 TEMPORIZADOR

**Esta função não pode ser utilizada com o forno desligado.**

Prima o botão ⏻.

O temporizador pisca.

Ajuste o temporizador com os botões + et -.

Prima o botão ⏻ para validar, e é iniciada a contagem regressiva.

Quando chega ao fim, é emitido um sinal sonoro.

Para parar, prima qualquer botão.

A hora volta a aparecer no visor.

NB: Tem a possibilidade de modificar ou anular a programação do temporizador a qualquer altura. Para anular, volte ao menu do temporizador e ajuste em 00:00. Sem validação, o registo é feito automaticamente ao fim de alguns segundos.

## 3.4 BLOQUEIO DO TECLADO

Prima simultaneamente os botões + e - até aparecer o símbolo 🔒 no ecrã. Para desbloquear, prima simultaneamente os botões + e - até o símbolo 🔒 desaparecer do ecrã.

4



Cozedura

### MODOS DE COZEDURA

(consoante o modelo)



#### CALOR VENTILADO\*

Temperatura mínima de 35°C e máxima de 235°C  
Recomendado para manter a tenrura de carnes brancas, peixes e legumes. Para as cozeduras múltiplas até 3 níveis.



#### PULSAÇÃO TRADICIONAL

Temperatura mínima de 35°C e máxima de 275°C  
Recomendado para carne, peixe, legumes, colocados de preferência num prato de barro.



#### GRELHA PULSADA

Temperatura mínima de 180°C e máxima de 230°C  
Aves e assados suculentos e estaladiços em todos os lados.

Deslize a pingadeira para o nível inferior.

Recomendado para todas as carnes de ave e assados, para tostar ou cozer na perfeição pernas de borrego, costeletas de vaca. Para manter o sabor nas pastas de peixe.



#### BASE PULSADA

Temperatura mínima de 75°C e máxima de 250°C  
Recomendado para pratos húmidos (quiches, tartes de fruta suculenta, etc.). A massa ficará bem cozida por baixo. Recomendado para preparações levedadas (bolo, brioche, foliar, etc.) e para soufflés que não sejam tapados com uma côdea.



### TRADICIONAL

Temperatura mínima de 35°C e máxima de 275°C  
Recomendado para cozaduras lentas e delicadas: animais de caça tenros. Para fazer assados de carnes vermelhas. Para engrossar numa panela tapada, para pratos preparados anteriormente sobre a placa (coq au vin, civet).



### ECO\*

Temperatura mínima de 35°C e máxima de 250°C  
Esta posição permite ganhar energia conservando as qualidades da cozedura.  
Todas as cozaduras são feitas sem preaquecimento.



### GRELHA FORTE



### GRELHA MÉDIA

Temperatura mínima de 180°C e máxima de 275°C  
Recomendados para grelhar tosta, gratinar um prato, dourar um leite creme...



### MANTER QUENTE

Temperatura mínima de 35°C e máxima de 100°C  
Recomendado para levdar massa para pão, brioche, foliar.  
Massa colocada sobre a base, sem ultrapassar os 40°C (aquece-pratos, descongelação).



### PIZZA

Temperatura mínima de 35°C e máxima de 275°C  
Faça um pré-aquecimento e depois, coloque no forno, no 3º encaixe.



### BOOST

Temperatura mínima de 35°C e máxima de 275°C  
Permite um preaquecimento rápido da cavidade.

*\*Modo de cozedura realizado de acordo com as prescrições da norma EN 60350-1 : 2016 para demonstrar a conformidade com as exigências de etiquetagem energética do regulamento europeu UE/65/2014.*



### Conselho de economia de energia

Em função  a lâmpada da cavidade apaga-se depois de 90 segundos. Durante a cozedura, mantenha a porta do forno fechada.

## A4.1 COZEDURA IMEDIATA

O programador deve apresentar apenas a hora. Esta não deve estar a piscar.  
Gire o seletor de funções para a posição desejada.  
A subida de temperatura arranca imediatamente. O forno tem uma temperatura predefinida, que pode ser alterada.  
O forno aquece e o indicador de temperatura pisca. Quando o forno atingir a temperatura programada, ouvirá uma série de sons.



## 4.2 MODIFICAÇÃO DA TEMPERATURA

Pressione  .









Ajuste a temperatura com + ou - .

Valide premindo  .

## 4.3 PROGRAMAÇÃO DA DURAÇÃO

Faça uma cozedura imediata e em seguida, pressione , a duração da cozedura  pisca e torna-se possível efetuar o acerto. Pressione + ou - para ajustar a duração da cozedura.

O seu forno está equipado com a função "SMART ASSIST" que sugere uma duração de cozedura modificável durante a programação da duração, modificável consoante o modo de cozedura selecionado. Consulte a tabela abaixo:

FUNÇÃO DE COZEDURA (consoante o modelo)	PREDEFINIÇÃO DE TEMPO
 TRADICIONAL	30 min
 PULSAÇÃO TRADICIONAL	30 min
 CALOR GIRATÓRIO	30 min
 BASE PULSADA	30 min
 ECO	30 min
 GRELHA MÉDIA	10 min
 GRELHA FORTE	7 min
 GRELHA PULSADA	15 min
 MANTER QUENTE	60 min
 PIZZA	15 min
 BOOST	5 min

A memorização do tempo de cozedura é automática após alguns segundos. A contagem da duração é feita imediatamente após ter sido atingida a temperatura de cozedura.

## 4.4 COZEDURA COM INÍCIO DIFERIDO

Proceda como para uma duração programada. Após o ajuste da duração da cozedura, pressione o botão  . O visor pisca, ajuste a hora de fim de cozedura com + ou - .

A memorização do fim da cozedura é automática após alguns segundos. O visor do fim da cozedura deixa de piscar.

## 5



## Limpeza

**LIMPEZA DA SUPERFÍCIE EXTERIOR**

Utilize um pano macio, embebido com um produto limpa-vidros. Não utilize cremes abrasivos nem esfregonas.

**LIMPEZA DO INTERIOR DO FORNO**

Limpe o forno ainda vazio com um pano humedecido com água com sabão e limpe com um pano sem pêlos.

**5.1 DESMONTAGEM DOS ENCAIXES E SUBSTITUIÇÃO DAS PAREDES CATALÍTICAS****Paredes laterais com encaixes de filamentos :**

Levante a parte anterior do encaixe de filamento em direção ao alto e coloque o conjunto do encaixe fazendo sair o gancho antes do compartimento do mesmo. Depois, puxe ligeiramente o conjunto do encaixe na sua direção para retirar os ganchos traseiros dos seus compartimentos. Retire os 2 encaixes e as **paredes catalíticas**. **Substitua os novos elementos (paredes) efetuando as operações inversas.**

**5.2 LIMPEZA DO VIDRO INTERIOR**

Para limpar o vidro interior, desmonte a porta. Antes de desmontar, retire o excesso de gordura do vidro interior com a ajuda de um pano macio e detergente da loiça.

**⚠ Cuidado**

**Não utilize produtos de limpeza abrasivos ou raspadores metálicos duros para limpar a porta em vidro do micro-ondas, pois isso pode riscar a superfície e levar à rutura do vidro.**

**DESMONTAGEM**

Abra completamente a porta e bloqueie-a com a ajuda de uma calha em plástico, fornecida na bolsa de plástico do seu aparelho.

Retire o vidro:

Pressione com a ajuda de uma ferramenta (aparafusadora) nos encaixes **A** para retirar o vidro. Retire o vidro.

Não imerja o vidro em água. Lave com água limpa e limpe com um pano que não perca pelos.

**NOVA MONTAGEM DA PORTA**

Após a limpeza, reposicione o vidro e encaixe nos batentes metálicos e em seguida, fixe-o com a face brilhante virada para o exterior.

Retire a calha de plástico.

O seu aparelho está novamente operacional.

**5.3 SUBSTITUIÇÃO DA LÂMPADA****Características da lâmpada:**

15 W, 220-240 V~, 300°C, culot E14.

Para desapertar a tampa e a lâmpada, utilize uma luva de borracha para facilitar a desmontagem.

**⚠ Cuidado:**

**Certifique-se de que o aparelho está desligado da alimentação antes de substituir a lâmpada, para evitar qualquer risco de choques elétricos. Intervenha quando o aparelho estiver frio.**

## 6

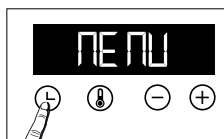

## Ajustes

**6.1 MENU**

Pode intervir em diferentes parâmetros do forno; para tal:

Pression o botão até aparecer "MENU" para aceder ao modo de

ajuste. Prima novamente o botão para ver os diferentes acertos.

Ative ou desative com os botões + e - os diferentes parâmetros, consultando a tabela abaixo:

	Ativar/desativar os sinais sonoros dos botões
	Ativar/desativar o modo de demonstração

Para sair de «MENU», prima novamente

## 7 ? Resolução de avarias

**O forno não aquece.** Verifique se o forno está bem ligado ou se o fusível da instalação não está fora de serviço. Aumente a temperatura seleccionada.

**A lâmpada do forno não funciona.** Substitua a lâmpada ou o fusível. Verifique se o forno está bem conectado.

**O ventilador de arrefecimento continua a girar depois do forno apagado.** É normal, a ventilação pode funcionar até uma hora no máximo após a cozedura, para fazer baixar a temperatura interior e exterior do forno. Depois de uma hora, deve contactar o serviço de assistência pós-venda.

## 8 Meio ambiente

### RESPEITO PELO MEIO AMBIENTE

Os materiais da embalagem deste aparelho são recicláveis. Participe na sua reciclagem contribuindo para a proteção do meio ambiente, eliminando-os nos contentores municipais previstos para o efeito.

O seu aparelho também contém vários materiais recicláveis. Assim, inclui este logótipo para indicar que os aparelhos usados não devem ser misturados com outros resíduos.



Assim, a reciclagem de aparelhos usados do fabricante será realizada nas melhores condições, em conformidade com a Diretiva Europeia 2002/96/CE em matéria de equipamentos eléctricos e electrónicos.

Consulte a sua câmara municipal ou o seu revendedor quanto aos pontos de recolha dos aparelhos usados mais próximos da sua habitação.

Agradecemos a sua colaboração na proteção do meio ambiente.

## 9 Serviço pós-venda

### INTERVENÇÕES

As eventuais intervenções no seu aparelho devem ser efetuadas por um profissional qualificado que trabalhe para a marca. Aquando da sua chamada, para facilitar o processamento do seu pedido, deve munir-se com as referências completas do seu aparelho (referência comercial, referência de serviço, número de série). Estas informações figuram na placa informativa.

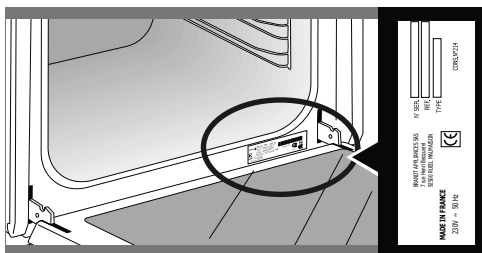

A		B		G	
SERVICE: C		TYPE: D			
E		F			
Nr. H				I	

B: Referência comercial

C: Referência de serviço















H: Número de série















### PEÇAS DE ORIGEM

No caso de uma intervenção, deve pedir a utilização exclusiva de **peças de substituição certificadas de origem**.





PRATOS	 *		 *		 *		 *		 *		 *		 *			
		NIVEL		NIVEL		NIVEL		NIVEL		NIVEL		NIVEL		NIVEL	min	
<b>Carnes</b>																
Assado de porco (1 kg)	200	2					180	2								60
Assado de vitela (1 kg)	200	2					180	2								60-70
Lombo de vaca assado	240	2														30-40
Borrego (perna, costela, 2,5 kg)	220	1			220						200	2				60
Aves (1 kg)	200	2			220		180	2			210	3				60
Grandes pedaços de aves	180	1														60-90
Coxas de frango					220	3					210	3				20-30
Costeleta de porco/vitela					210	3										20-30
Costeletas de vaca (1 kg)					210	3					210	3				20-30
Costeletas de carneiro					210	3										20-30
<b>Peixes</b>																
Peixe grelhado					275	4										15-20
Peixe cozinhado	200	3					180	3								30-35
Peixe em papilote	220	3					200	3								15-20
<b>Legumes</b>																
Gratinados (alimentos cozinhados)					275	2										30
Batatas gratinadas	200	2					180	2								45
Lasanha	200	3					180	3								45
Tomates recheados	170	3					160	2								30
<b>Bolos</b>																
Pão-de-ló - Bolo Génoise			180	2								180	2			35
Torta	220	3										180	2			5-10
Brioche	180	1	210									180	2			35-45
Brownies	180	2					175	3								20-25
Pão de ló	180	1	180	1								180	2			45-50
Clafouti	200	2					180	3								30-35
Cremes	165	2										150	2			30-40
Biscoito - areados	175	3														15-20
Folar			180	2								180	2			40-45
Merengues	100	2										100	3			60-70
Madalenas	220	3					200	3								5-10

PRATOS	 *		 *		 *		 *		 *		 *		 *		 *	
		NIVEL		NIVEL		NIVEL		NIVEL		NIVEL		NIVEL		NIVEL	min	
<b>Bolos</b>																
Madalenas	220	3					200	3								5-10
Massa dos sonhos	200	3					180	3					180	3		30-40
Petiscos de massa folhada	220	3					200	3								5-10
Savarin	180	3											175	3		30-35
Tarte de massa quebrada	200	1					195	1								30-40
Tarte de massa folhada fina	215	1					200	1								20-25
Tarte de massa com fermento	210	1					200	1								10-30
<b>Diversos</b>																
Espetadas	220	3			210	4										10-15
Paté em terrina	200	2					190	2								80-100
Pizza de massa quebrada	200	2														30-40
Pizza de massa de pão																15-18
Quiches																35-40
Soufflé													180	2		50
Tortas	200	2														40-45
Pão	220						200		220							30-40
Pão grelhado	180				275	4-5										2-3
Tachos fechados (ensopado)	180	2											180	2		90-180

\* Consoante o modelo

**Todas as temperaturas e tempos de cozedura são dados para fornos pré-aquecidos**

N.B: Antes de serem colocadas no forno, todas as carnes devem ficar pelo menos uma hora à temperatura ambiente.

**EQUIVALÊNCIA: VALORES °C**

°C	30	60	90	120	150	180	210	240	275
<b>Valores</b>	<b>1</b>	<b>2</b>	<b>3</b>	<b>4</b>	<b>5</b>	<b>6</b>	<b>7</b>	<b>8</b>	<b>9 max.</b>

## Receita com fermento (consoante o modelo)

Ingredientes:

● Farinha 2 kg ● Água 1240 ml ● Sal 40 g ● 4 pacotes de fermento de padeiro desidratado







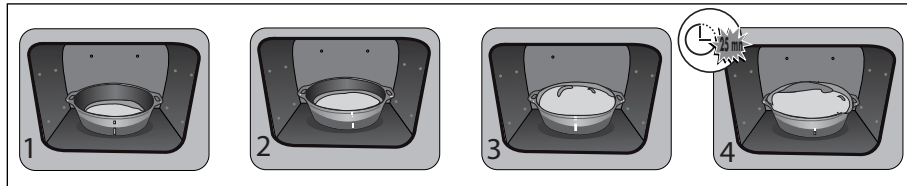











Misturar a massa com a batedeira e deixar levedar no forno.

**Procedimento:** Para as receitas de massas com fermento. Verter a massa num prato resistente ao calor, retirar os suportes dos encaixes e colocar o prato no fundo.

**Pré-aquecer o forno com a função de calor ventilado a 40-50°C durante 5 minutos. Desligar o forno e deixar levedar a massa durante 25-30 minutos graças ao calor residual.**



## ENSAIOS DE APTIDÃO PARA A FUNÇÃO SE- GUNDO A NORMA IEC 60350

ALIMENTO	* Modos de cozedura	ENCAIXE	ACESSORIOS	T°C	TEMPO	Pré-aquecimento
Bolos secos (8.4.1)		5	Placa 45 mm	150	30-40	SIM
Bolos secos (8.4.1)		5	Placa 45 mm	150	25-35	SIM
Bolos secos (8.4.1)		2 + 5	Placa 45 mm + Grelha	150	25-45	SIM
Bolos secos (8.4.1)		3	Placa 45 mm	175	25-35	SIM
Bolos secos (8.4.1)		2 + 5	Placa 45 mm + Grelha	160	30-40	SIM
Queques (8.4.2)		5	Placa 45 mm	170	25-35	SIM
Queques (8.4.2)		5	Placa 45 mm	170	25-35	SIM
Queques (8.4.2)		2 + 5	Placa 45 mm + Grelha	170	20-40	SIM
Queques (8.4.2)		3	Placa 45 mm	170	25-35	SIM
Queques (8.4.2)		2 + 5	Placa 45 mm + Grelha	170	25-35	SIM
Génoise sem matéria gorda (8.5.1)		4	Grelha	150	30-40	SIM
Génoise sem matéria gorda (8.5.1)		4	Grelha	150	30-40	SIM
Génoise sem matéria gorda (8.5.1)		2 + 5	Placa 45 mm + Grelha	150	30-40	SIM
Génoise sem matéria gorda (8.5.1)		3	Grelha	150	30-40	SIM
Génoise sem matéria gorda (8.5.1)		2 + 5	Placa 45 mm + Grelha	150	30-40	SIM
Torta de maçã (8.5.2)		1	Grelha	170	90-120	SIM
Torta de maçã (8.5.2)		1	Grelha	170	90-120	SIM
Torta de maçã (8.5.2)		3	Grelha	180	90-120	SIM
Pão torrado (9.2.2)		5	Grelha	275	3-6	SIM

\* de acordo com o modelo

**NOTA:** Para cozeduras a dois níveis, os pratos podem ser retirados em alturas diferentes.



Estimado/a cliente/a,

Le agradecemos la confianza que ha depositado en nosotros al adquirir este producto **BRANDT**.

Hemos diseñado y fabricado este producto pensando en usted, en su modo de vida y en sus necesidades para poder satisfacer mejor sus expectativas. animados por el espíritu innovador y la pasión que nos caracteriza desde hace más de 60 años.

Para responder a todas sus necesidades, tenemos un servicio de atención al cliente a su disposición que atenderá todas sus preguntas y sugerencias.

También puede visitar nuestra página web [www.brandt.com](http://www.brandt.com) donde encontrará nuestras últimas novedades, así como información útil y complementaria.

**En BRANDT** nos sentimos orgullosos de acompañarle en su día a día y le deseamos que disfrute plenamente de su compra.



**Importante: Antes de utilizar el aparato por primera vez, lea atentamente este manual para familiarizarse más rápidamente con su funcionamiento.**

## INSTRUCCIONES DE SEGURIDAD

### INSTRUCCIONES DE SEGURIDAD IMPORTANTES - LÉALAS CON ATENCIÓN Y CONSERVELAS PARA CONSULTARLAS EN EL FUTURO.

Este manual se encuentra disponible para descarga en la página web de la marca.



Cuando reciba el aparato, desembálelo o hágalo desembalar inmediatamente. Compruebe su aspecto general. Si tiene reservas que señalar, hágalo por escrito en el albarán de entrega y quédese con un ejemplar.

#### Importante:

Este aparato se puede utilizar por niños de 8 años y más y por personas con capacidades físicas, sensoriales o mentales reducidas o carentes de la experiencia y del conocimiento si han podido beneficiar de una vigilancia o de instrucciones previas sobre la utilización del aparato de forma segura y han comprendido los riesgos incurridos.

— Los niños no deben jugar con el aparato. Las operaciones de limpieza y de mantenimiento no deben ser realizadas por niños sin vigilancia.

— Conviene vigilar a los niños para asegurarse de que no jueguen con el aparato.

#### ADVERTENCIA:

— El aparato y sus partes accesibles se calientan durante la utilización. No debe tocar los elementos calientes situados en el interior del horno. Mantenga alejados a los niños menores de 8 años o vigílelos permanentemente.

— Este aparato ha sido diseñado

para realizar cocciones con la puerta cerrada.

— Antes de proceder a la limpieza con función pirólisis del horno, retire todos los accesorios y elimine las salpicaduras importantes.

— Durante una limpieza, las superficies accesibles se calientan más que durante un uso normal.

Se recomienda alejar a los niños.

— No utilice un aparato de limpieza a vapor.

— No utilice productos de limpieza abrasivos ni estropajos metálicos duros para limpiar la puerta de cristal del horno, ya que podrían rayar la superficie y provocar la rotura del cristal.



#### ADVERTENCIA :

Para evitar cualquier riesgo de electrocución, asegúrese de que el aparato esté desconectado de la alimentación antes de cambiar la bombilla. Realice la intervención cuando el aparato se haya enfriado. Para desatornillar la tulipa y la bombilla, utilice un guante de goma que facilitará el desmontaje.

El enchufe debe estar accesible después de realizar la instalación. El aparato se debe poder desconectar de la red eléctrica, bien por medio de un enchufe o bien incorporando un interruptor en

## INSTRUCCIONES DE SEGURIDAD

las canalizaciones fijas siguiendo las normas de instalación.

 — Si el cable de alimentación está dañado, debe ser reemplazado por el fabricante, su servicio de postventa o una persona de calificación similar para evitar un peligro.

— Este aparato puede instalarse indiferentemente bajo un plano o en una columna tal como se indica en el esquema de instalación.

— Centre el horno en el mueble respetando una distancia mínima de 5 mm con el mueble contiguo. El material del mueble de empotramiento debe ser resistente al calor (o estar recubierto con un material resistente). Para más estabilidad, fije el horno en el mueble con 2 tornillos, a través de los orificios previstos para dicho fin en los montantes laterales.

— El aparato no debe instalarse detrás de una puerta decorativa, con el fin de evitar un recalentamiento.

— Este aparato está destinado para ser utilizado en aplicaciones domésticas y análogas como: Pequeñas cocinas reservadas al personal de tiendas, oficinas y entornos profesionales.

Granjas. La utilización por clientes de hoteles, moteles y otros entornos de carácter residencial, entornos de tipo habitaciones de huéspedes.

— Para cualquier intervención de limpieza en la cavidad del horno,

éste debe estar apagado.

No modifique las características de este aparato; hacerlo representaría un peligro para usted.

No utilice el horno como despensa o para guardar accesorios después de su utilización.

# 1 Presentación del horno

## 1.1 PRESENTACIÓN DEL HORNO

- A** Panel de mandos
- B** Lámpara
- C** Puerta
- D** Empuñadura

Este horno dispone de 6 posiciones de niveles para los accesorios: niveles 1 a 6.

## 1.2 PANTALLA



- Tiempo de cocción
- Fin de la cocción
- Bloqueo del teclado
- Temporizador
- °C** Indicador de temperatura
- Indicador de precalentado
- Bloqueo de la puerta

## 1.3 TECLAS

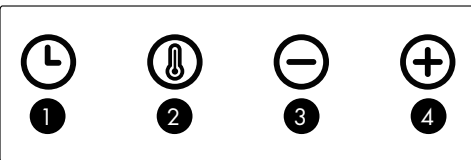

- 1** Selección de hora y tiempo
- 2** Selección de temperatura
- 3** Tecla -
- 4** Tecla +

## 1.4 ACCESORIOS (según el modelo)

### A • Parrilla de seguridad antivuelco

La parrilla se puede utilizar como soporte para bandejas y fuentes con alimentos para asar o gratinar. También se puede utilizar para asados a la parrilla (que se colocarán directamente encima).

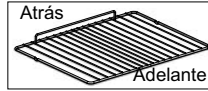

Introduzca la parrilla de seguridad antivuelco hacia el fondo del horno.

### B • Bandeja multiusos recogejugos de 45 mm

Se inserta en los niveles por debajo de la parrilla con la empuñadura hacia la puerta del horno. Recoge los jugos y grasas de los asados; también se puede utilizar llena de agua hasta la mitad para cocciones al baño maría.

### C • Bandeja de repostería de 20 mm

Se inserta en los niveles con la empuñadura hacia la puerta del horno. Ideal para la cocción de galletas, pastas y cupcakes. Su superficie inclinada le permite depositar fácilmente sus preparados en el plato. También puede insertarse en los niveles por debajo de la parrilla para recoger los jugos y grasas de los alimentos preparados a la parrilla.

### Consejo

**Con el fin de evitar emisiones de humo durante la cocción de carnes grasas, le recomendamos añadir una pequeña cantidad de agua o de aceite en el fondo de la bandeja recogejugos.**

# 2 Instalación

## 2.1 ELECCIÓN DEL EMPLAZAMIENTO Y EMPOTRAMIENTO

Los esquemas determinan las cotas de un mueble en el que será posible colocar el horno. Este aparato se puede instalar indistintamente bajo una encimera (**A**) o en columna (**B**). Si el mueble está abierto, su apertura debe ser de 70 mm como máximo en su parte posterior.

Fije el horno al mueble. Para ello, retire los topes de goma y perforo un orificio de Ø 2 mm en la pared del mueble para evitar que se agriete la madera. Fije el horno con los 2 tornillos. Vuelva a colocar los topes de goma.

### Consejo

**Para estar seguro de que la instalación es adecuada, no dude en recurrir a un especialista en electrodomésticos.**

### Atención

**Antes de utilizar el horno por primera vez, hay que calentarlo vacío a 200°C durante 1 hora aproximadamente. Compruebe que la estancia esté bien aireada.**

## CONEXIÓN ELÉCTRICA

El horno debe estar conectado con un cable de alimentación normalizado con 3 conductores de 1,5 mm<sup>2</sup> (1 f + 1 N + tierra) conectados a la red de 220~240 voltios por medio de una toma de corriente normalizada CEI 60083 o de un dispositivo de corte omnipolar de acuerdo con las normas de instalación.

El cable de protección (verde-amarillo) va conectado al borne  del aparato y también hay que conectarlo a la tierra de la instalación. El fusible de la instalación debe ser de 16 amperios. No se asumirá ningún tipo de responsabilidad en caso de accidente o incidente debido a una falta de conexión de toma de tierra o a una toma de tierra defectuosa o incorrecta, ni en el caso de una conexión incorrecta.

 **Atención:**  
Si la instalación eléctrica de la habitación obliga a efectuar una modificación para poder conectar el aparato, llame a un electricista cualificado. Si el horno presenta alguna anomalía, desconecte el aparato o quite el fusible correspondiente a la línea de conexión del horno.

## 3 Puesta en hora

### 3.1 PUESTA EN HORA

Al conectar el aparato, la pantalla parpadea a las 12:00.



Establezca la hora con las teclas + o -.

Confírmela con la tecla .

En caso de un corte de corriente, la visualización de la hora parpadeará para indicarle la hora del corte.

### 3.2 CAMBIO DE LA HORA

El selector de función debe estar obligatoriamente en la posición 0.

Pulse la tecla  y aparecerá el símbolo del temporizador . Vuelva a pulsar  y ajuste la hora con las teclas + o -.

Confírmela con la tecla .

### 3.3 TEMPORIZADOR

**Esta función únicamente puede utilizarse con el horno apagado.**

Pulse la tecla .

Parpadeará el símbolo del temporizador .

Ajuste el temporizador con las teclas + o -.



Pulse la tecla  para confirmar y comenzará la cuenta atrás.

Una vez transcurrido el tiempo, se emite una señal

acústica. Para detenerla, pulse cualquier tecla. La hora volverá a aparecer en la pantalla.

N.B.: Tiene la posibilidad de modificar o anular la programación del temporizador en cualquier momento. Para anularlo, vuelva al menú del temporizador y ajústelo en 00:00. Sin confirmación, el último ajuste quedará automáticamente registrado al cabo de unos segundos.

## 3.4 BLOQUEO DEL TECLADO

Pulse simultáneamente las teclas + y - hasta que aparezca el símbolo  en la pantalla. Para desbloquearlo, pulse simultáneamente las teclas + y - hasta que desaparezca el símbolo  de la pantalla.

## 4 Cocción

### MODOS DE COCCIÓN

(según modelo)

#### CALOR GIRATORIO\*

Temperatura mínima de 35°C, máxima de 235°C  
Recomendado para conservar la ternura de la carne blanca, el pescado y las verduras. Para las cocciones múltiples de hasta 3 niveles.

#### TRADICIONAL CON AIRE IMPULSADO

Temperatura mínima de 35°C, máxima de 275°C  
Recomendado para carne, pescado y verduras, colocados preferentemente en una fuente de barro.

#### GRILL CON AIRE IMPULSADO

Temperatura mínima de 180°C, máxima de 230°C  
Aves y asados jugosos y crujientes por todos los lados. Coloque la bandeja recogejugos en el nivel más bajo. Recomendado para todas las aves o asados hechos, para soasar y cocinar hasta el centro piernas de cordero, chuletas de buey. Para que las piezas de pescado queden jugosas y tiernas.

#### SOLERA CON AIRE IMPULSADO

Temperatura mínima de 75°C, máxima de 250°C  
Recomendado para platos húmedos (quiches, tartas de frutas jugosas, etc.). La masa quedará bien cocida por debajo. Recomendado para las preparaciones que deben subir (cake, brioche, kouglof...) así como para los soufflés, que no quedarán bloqueados por la costra formada encima.



**TRADICIONAL**

Temperatura mínima de 35°C, máxima de 275°C  
 Recomendado para las cocciones lentas y delicadas: caza tierna, etc. Para soasar asados de carne roja. Para cocer a fuego lento en una cacerola cerrada los platos previamente cocinados en la placa de cocción (gallo al vino, liebre, etc.).



**ECO\***

Temperatura mínima de 35°C, máxima de 250°C  
 Esta posición permite ahorrar energía conservando las cualidades de la cocción.  
 Todas las cocciones se realizan sin precalentamiento.



**GRILL FUERTE**



**GRILL MEDIO**

Temperatura mínima de 180°C, máxima de 275°C  
 Recomendado para tostar pan, gratinar un plato, dorar una crema catalana, etc.



**MANTENIMIENTO EN CALIENTE**

Temperatura mínima de 35°C, máxima de 100°C  
 Recomendado para que suban las masas de pan, de brioche, kouglof.  
 El molde se coloca en la placa sin superar los 40°C (calienta-platos, descongelación).



**PIZZA**

Temperatura mínima de 35°C, máxima de 275°C  
 Con el fin de garantizar un buen resultado en sus pizzas, introdúzcalas en el tercer nivel con el horno caliente.



**BOOST**

Temperatura mínima de 35°C, máxima de 275°C  
 Permite un aumento rápido en la temperatura de la cavidad del horno.

*\*Modo de cocción efectuado siguiendo las indicaciones de la norma EN 60350-1: 2016 para demostrar el cumplimiento de las exigencias de etiquetado energético de la normativa europea UE/65/2014.*



**Consejo**

**Con la función ECO, 90 segundos después de cerrar la puerta o de iniciarse una cocción, la luz del horno se apaga.**

**4.1 COCCIÓN INMEDIATA**

El programador solo debe indicar la hora. Ésta no debe parpadear.

Gire el selector de funciones a la posición seleccionada.

El aumento de temperatura comenzará inmediatamente. Su horno le recomendará una temperatura modificable.

El horno calentará y el indicador de la temperatura parpadeará. Cuando haya alcanzado la temperatura programada, emitirá una serie de pitidos.

**4.2 MODIFICACIÓN DE LA TEMPERATURA**

Pulse . Ajuste la temperatura con + o -.

Confírmela pulsando .

**4.3 PROGRAMACIÓN DEL TIEMPO**

Efectúe una cocción inmediata y después pulse . El tiempo de cocción parpadeará y permitirá ajustarlo. Pulse + o - para ajustar el tiempo de cocción.

Su horno está equipado con la función «**SMART ASSIST**» la cual le recomendará durante la programación del tiempo, un tiempo modificable en función de la cocción seleccionada.

Consulte la siguiente tabla:

FUNCIÓN DE COCCIÓN (según modelo)	RECOMENDACIÓN DE TIEMPO
TRADICIONAL	30 min
TRADICIONAL CON AIRE IMPULSADO	30 min
CALOR GIRATORIO	30 min
SOLERA CON AIRE IMPULSADO	30 min
ECO	30 min
GRILL MEDIO	10 min
GRILL FUERTE	7 min
GRILL CON AIRE IMPULSADO	15 min
MANTENIMIENTO EN CALIENTE	60 min
PIZZA	15 min
BOOST	5 min

El tiempo de cocción quedará automáticamente registrado al cabo de unos segundos. La cuenta atrás se inicia inmediatamente una vez alcanzada la temperatura de cocción.

## 4.4 COCCIÓN CON INICIO DIFERIDO

Proceda igual que para un tiempo programado. Tras ajustar el tiempo de cocción, pulse la tecla  y la pantalla parpadeará. Ajuste la hora de fin de cocción con + o -.

El final de cocción quedará automáticamente registrado al cabo de unos segundos. La pantalla de fin de cocción deja de parpadear.

## 5 Limpieza

### LIMPIEZA DE LA SUPERFICIE EXTERIOR

Utilice un paño suave empapado con limpiacristales. No utilice cremas abrasivas, ni estropajos.

### LIMPIEZA DEL INTERIOR DEL HORNO

Limpie el horno cuando esté aún algo caliente con un paño humedecido con agua y jabón y séquelo con un paño que no suelte pelusa.

## 5.1 DESMONTAJE DE LOS NIVELES Y SUSTITUCIÓN DE LAS PAREDES CATALÍTICAS.

### Paredes laterales con paneles de varillas :

Levante la parte delantera del panel de varillas, empújelo y haga salir el gancho delantero de su alojamiento. Tire después cuidadosamente del panel de varillas hacia usted para hacer salir los ganchos posteriores de su alojamiento. Retire también los 2 niveles y **las paredes catalíticas. Vuelva a colocar los nuevos elementos (paredes) efectuando las operaciones inversas.**

## 5.2 LIMPIEZA DEL CRISTAL INTERIOR

Para limpiar el cristal interior desmonte la puerta. Antes de desmontarlos, retire el exceso de grasa del cristal interior con un paño suave y un lavavajillas.

### Advertencia

**No utilice productos de limpieza abrasivos, nanas ni raspadores metálicos para limpiar la puerta de cristal del horno, ya que se podría rayar la superficie y hacer que estallara el cristal.**

### DESMONTAJE

Abra la puerta por completo y bloquéela con la cuña de plástico incluida en la bolsa de plástico de su aparato.

Extraiga el cristal enganchado:

Presione con una herramienta (destornillador) en los puntos **A** para desenganchar el cristal.

Extraiga el cristal.

No sumerja el cristal en el agua. Aclárelo con agua limpia y séquelo con un trapo que no suelte pelusa.

### REINSTALACIÓN DE LA PUERTA

Tras la limpieza, vuelva a colocar el cristal en los topes metálicos y engánchelo con la cara brillante hacia el exterior.

Retire la cuña de plástico.

El aparato ya está nuevamente operativo.

## 5.3 CAMBIO DE LA LÁMPARA

### Advertencia:

**Para evitar cualquier riesgo de electrocución, asegúrese de que el aparato esté desconectado de la alimentación antes de cambiar la lámpara. Realice la intervención cuando el aparato se haya enfriado.**

### Características de la bombilla:

15 W, 220-240 V~, 300°C, casquillo E14.

Para desatornillar el plafón y la bombilla, utilice un guante de goma que facilitará el desmontaje.

## 6 Ajustes

### 6.1 MENÚ

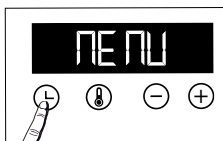



Puede modificar diferentes parámetros de su horno, para ello:

Pulse la tecla  hasta que aparezca "MENÚ" para acceder al modo de















ajustes. Vuelva a pulsar la tecla  para desplazarse por los diferentes ajustes.

Active o desactive con las teclas + y - los diferentes parámetros. Consulte la siguiente tabla:















	Activar/desactivar los tonos de las teclas
	Activar/desactivar el modo de demostración

Para salir del «MENÚ», pulse de nuevo .



PLATOS	 *		 *		 *		 *		 *		 *		 *			
		GALTURA		GALTURA		GALTURA		GALTURA		GALTURA		GALTURA		GALTURA	min	
<b>Carne</b>																
Asado de cerdo (1kg)	200	2					180	2								60
Asado de ternera (1kg)	200	2					180	2								60-70
Asado de buey	240	2														30-40
Cordero (pata, paletilla 2,5 kg)	220	1		220						200	2					60
Aves (1 kg)	200	2		220		180	2			210	3					60
Aves grandes piezas	180	1														60-90
Muslos de pollo				220	3					210	3					20-30
Costillas de cerdo / ternera				210	3											20-30
Costillas de buey (1kg)				210	3					210	3					20-30
Costillas de cordero				210	3											20-30
<b>Pescados</b>																
Pescados asados				275	4											15-20
Pescados cocinados (dorada)	200	3				180	3									30-35
Pescados en papillote	220	3				200	3									15-20
<b>Verduras</b>																
Gratenes (alimentos cocinados)				275	2											30
Gratenes «dauphinois»	200	2				180	2									45
Lasañas	200	3				180	3									45
Tomates rellenos	170	3				160	2									30
<b>Pasteles</b>																
Bizchocho esponjoso - Tarta			180	2								180	2			35
Brazo de gitano	220	3										180	2		5-10	
Brioche	180	1	210									180	2		35-45	
Brownies	180	2				175	3								20-25	
Bizchocho - cuatro cuartos	180	1	180	1								180	2		45-50	
Tarta de cerezas	200	2				180	3								30-35	
Cremas	165	2										150	2		30-40	
Galletas - Polvorones	175	3													15-20	
Kugelhopf			180	2								180	2		40-45	
Merengues	100	2										100	3		60-70	
Magdalenas	220	3				200	3								5-10	

\* según modelo

PLATOS	 *		 *		 *		 *		 *		 *		 *		 *	
		GALTURA		GALTURA		GALTURA		GALTURA		GALTURA		GALTURA		GALTURA	min	
<b>Pasteles</b>																
Magdalenas	220	3					200	3								5-10
Masa de buñuelos	200	3					180	3					180	3		30-40
Pastas hojaldradas	220	3					200	3								5-10
Pastel Savarin	180	3											175	3		30-35
Tarta de masa quebrada	200	1					195	1								30-40
Tarta de hojaldre fino	215	1					200	1								20-25
Tarta de masa con levadura	210	1					200	1								10-30
<b>Varios</b>																
Pinchos	220	3			210	4										10-15
Paté en terrina	200	2					190	2								80-100
Pizza masa quebrada	200	2														30-40
Pizza masa de pan																15-18
Quiches																35-40
Suflé													180	2		50
Empanadas	200	2														40-45
Pan	220						200		220							30-40
Pan tostado	180				275	4-5										2-3
Ollas cerradas (estofados)	180	2											180	2		90-180

\* según modelo



**CALIENTE PREVIAMENTE EL HORNO ANTES DE INTRODUCIR LAS BANDEJAS**

Antes de introducirla en el horno, todas las carnes deben estar al menos 1 hora a temperatura ambiente.

EQUIVALENCIA : CIFRAS  °C									
°C	30	60	90	120	150	180	210	240	275
Cifras	1	2	3	4	5	6	7	8	9 maxi

## Receta con levadura (según el modelo)

Ingredientes:

● 2 kg de harina ● 1.240 ml de agua ● 40 g de sal ● 4 paquetes de levadura de panadería deshidratada.







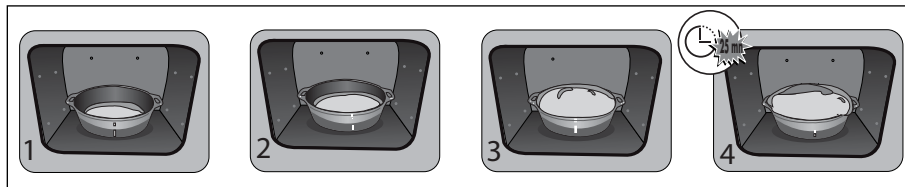











Mezcle la masa con la mezcladora y haga subir la masa en el horno.

**Procedimiento:** Para las recetas de masa con levadura. Vierta la masa en una fuente resistente al calor, retire los paneles de varillas y coloque la fuente en la placa.

**Precaliente el horno con la función de calor giratorio a 40-50°C durante 5 minutos. Apague el horno y deje que la masa suba durante 25-30 minutos con el calor residual.**



## PRUEBAS DE APTITUD A LA FUNCION SEGUN NORMA CEI 60350

ALIMENTO	*MODOS DE COCCION	NIVEL	Accesorios	°C	TIEMPO min.	PRECALENTAMIENTO
Galletas de mantequilla (8.4.1)		5	bandeja 45 mm	150	30-40	SI
Galletas de mantequilla (8.4.1)		5	bandeja 45 mm	150	25-35	SI
Galletas de mantequilla (8.4.1)		2 + 5	bandeja 45 mm + parilla	150	25-45	SI
Galletas de mantequilla (8.4.1)		3	bandeja 45 mm	175	25-35	SI
Galletas de mantequilla (8.4.1)		2 + 5	bandeja 45 mm + parilla	160	30-40	SI
Magdalenas (8.4.2)		5	bandeja 45 mm	170	25-35	SI
Magdalenas (8.4.2)		5	bandeja 45 mm	170	25-35	SI
Magdalenas (8.4.2)		2 + 5	bandeja 45 mm + parilla	170	20-40	SI
Magdalenas (8.4.2)		3	bandeja 45 mm	170	25-35	SI
Magdalenas (8.4.2)		2 + 5	bandeja 45 mm + parilla	170	25-35	SI
Bizcocho esponjoso sin grasa (8.5.1)		4	parilla	150	30-40	SI
Bizcocho esponjoso sin grasa (8.5.1)		4	parilla	150	30-40	SI
Bizcocho esponjoso sin grasa (8.5.1)		2 + 5	bandeja 45 mm + parilla	150	30-40	SI
Bizcocho esponjoso sin grasa (8.5.1)		3	parilla	150	30-40	SI
Bizcocho esponjoso sin grasa (8.5.1)		2 + 5	bandeja 45 mm + parilla	150	30-40	SI
Tarta de manzana (8.5.2)		1	parilla	170	90-120	SI
Tarta de manzana (8.5.2)		1	parilla	170	90-120	SI
Tarta de manzana (8.5.2)		3	parilla	180	90-120	SI
Superficie de gratinado (9.2.2)		5	parilla	275	3-6	SI

\* según modelo

**NOTA :** Para cocinar sobre 2 niveles, se puede salir los platos a diferentes momentos.

Service fourni par BRANDT FRANCE, Etablissement de CERGY, 5/7 avenue des Béthunes, 95310 SAINT OUEN L'AUMÔNE.  
SAS au capital social de 100.000.000 euros RCS NANTERRE 801 250 531.

CZ5703255-00 06-2017